

DATA SHEET



Three Phase Induction Motor - Squirrel Cage

Customer : Dealers Industrial Equipment 800-469-3110		Customer reference : 12536OT3H404TS-W40				
Product line : W40 NEMA Premium Efficiency Three-Phase		Product code : 14272436	Catalog # : 12536OT3H404TS-W40			
Frame : 404/5TS Output : 125 HP Poles : 2 Frequency : 60 Hz Rated voltage : 575 V Rated current : 109 A L. R. Amperes : 740 A LRC : 6.8x(Code G) No load current : 28.8 A Rated speed : 3557 rpm Slip : 1.19 % Rated torque : 182 ft.lb Locked rotor torque : 170 % Breakdown torque : 260 % Insulation class : F Service factor : 1.25 Moment of inertia (J) : 8.23 sq.ft.lb Design : B	Locked rotor time : 21s (cold) 12s (hot) Temperature rise : 80 K Duty cycle : Cont.(S1) Ambient temperature : -20°C to +40°C Altitude : 1000 m.a.s.l. Protection degree : IP23 Cooling method : IC01 - ODP Mounting : F-1 Rotation ¹ : Both (CW and CCW) Noise level ² : 84.0 dB(A) Starting method : Direct On Line Approx. weight ³ : 861 lb					
Output	25%	50%	75%	100%	Foundation loads	
Efficiency (%)	92.8	93.0	94.1	94.1	Max. traction : 1008 lb	
Power Factor	0.57	0.79	0.86	0.88	Max. compression : 1869 lb	
		<u>Drive end</u>		<u>Non drive end</u>		
Bearing type	:	6314 C3		6212 Z C3		
Sealing	:	Without Bearing Seal		Without Bearing Seal		
Lubrication interval	:	14418 h		20000 h		
Lubricant amount	:	27 g		13 g		
Lubricant type	:	Mobil Polyrex EM				
Notes downloaded from http://dealerselectric.com						
This revision replaces and cancel the previous one, which must be eliminated. (1) Looking the motor from the shaft end. (2) Measured at 1m and with tolerance of +3dB(A). (3) Approximate weight subject to changes after manufacturing process. (4) At 100% of full load.			These are average values based on tests with sinusoidal power supply, subject to the tolerances stipulated in NEMA MG-1.			
Rev.	Changes Summary			Performed	Checked	Date
Performed by						
Checked by					Page	Revision
Date	15/04/2019				1 / 2	

LOAD PERFORMANCE CURVE



Three Phase Induction Motor - Squirrel Cage

Customer : Dealers Industrial Equipment 800-469-3110
 Customer reference : 12536OT3H404TS-W40

Product line : W40 NEMA Premium Efficiency Three-Phase Product code : 14272436
 Catalog # : 12536OT3H404TS-W40

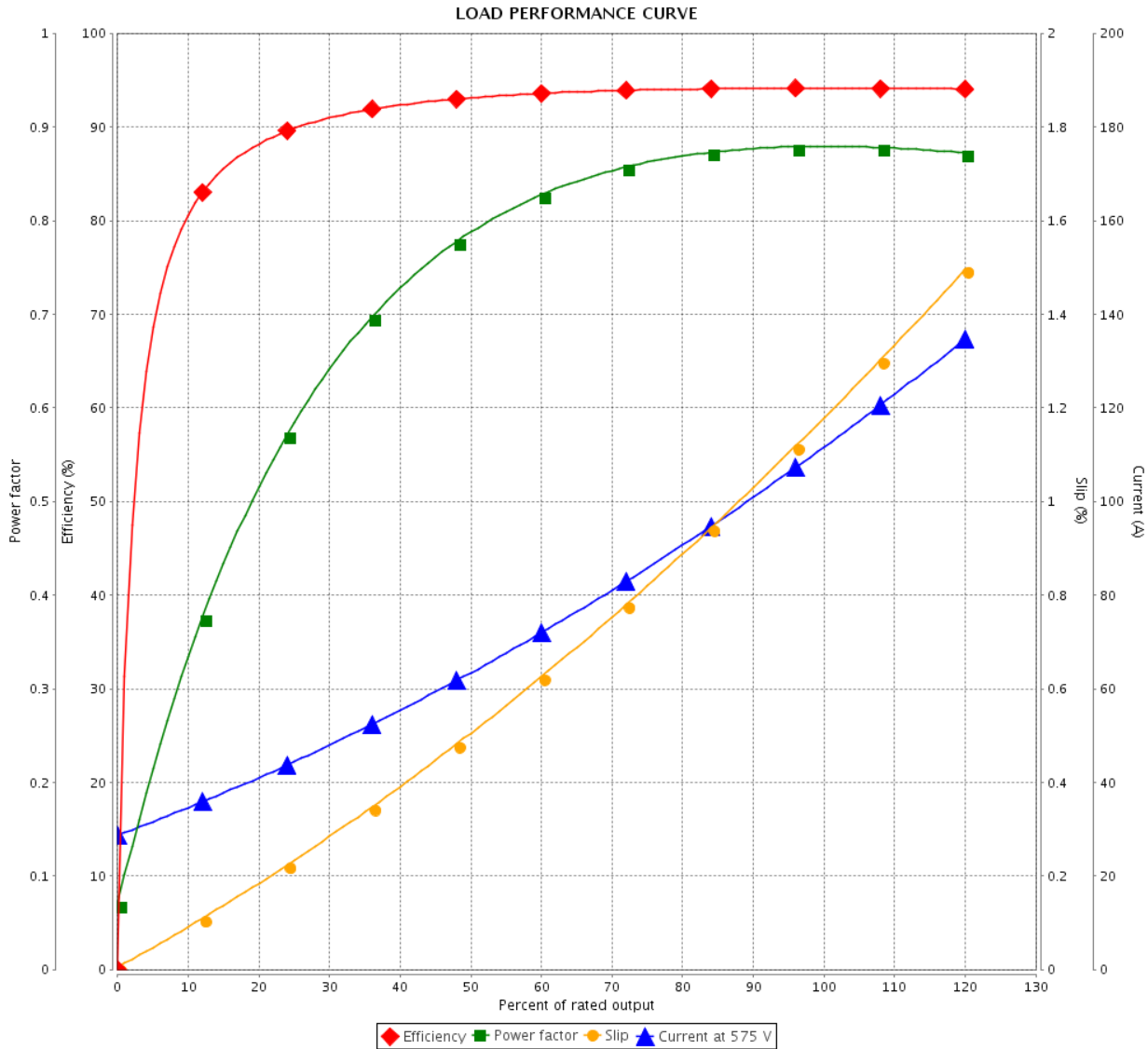

Performance : 575 V 60 Hz 2P

Rated current : 109 A	Moment of inertia (J) : 8.23 sq.ft.lb
LRC : 6.8	Duty cycle : Cont.(S1)
Rated torque : 182 ft.lb	Insulation class : F
Locked rotor torque : 170 %	Service factor : 1.25
Breakdown torque : 260 %	Temperature rise : 80 K
Rated speed : 3557 rpm	Design : B

Rev.	Changes Summary	Performed	Checked	Date
Performed by			Page 2 / 2	Revision
Checked by				
Date	15/04/2019			

Dimensões em polegada
Dimensions in inches

THIS IS AN UPDATED REVISION, THE
PREVIOUS ONE MUST BE DISREGARDED.

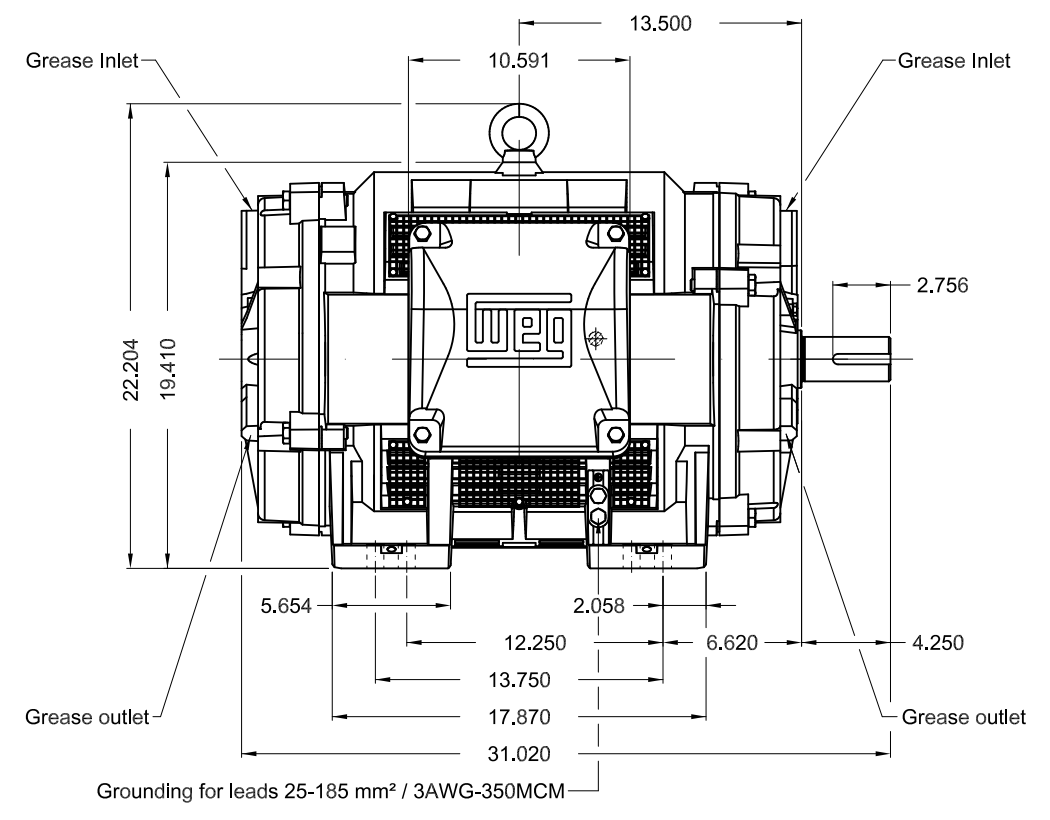
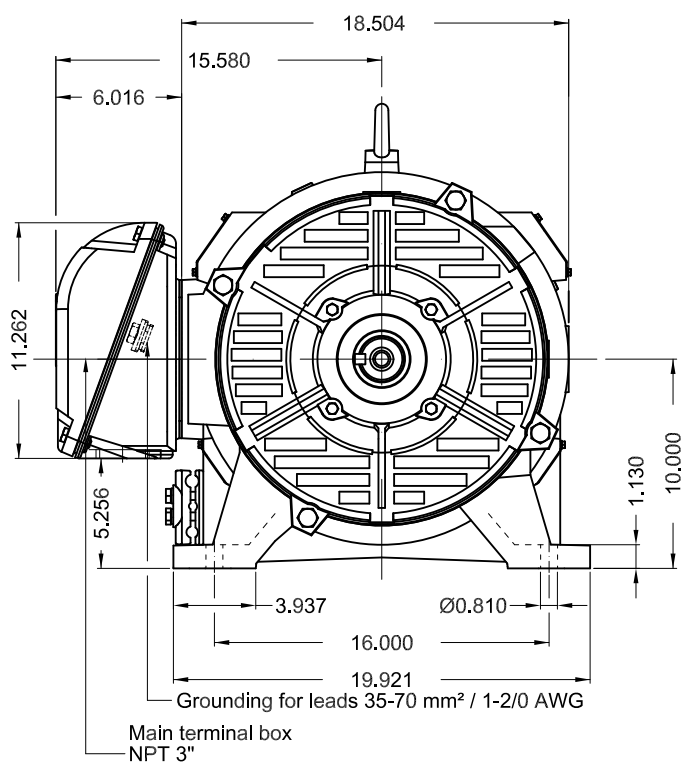

Color RAL 5009									
Painting plan 203A									
Mounting B3R(D)									
					SCALE	1:9			
ECM	LOC	SUMMARY OF MODIFICATIONS			EXECUTED	CHECKED	RELEASED	DATE	VER
EXECUTED	USERADMIN	THREE PHASE W40 MOTOR NEMA PREMIUM EFF							
CHECKED		FRAME 404/5TS IP23 ODP							
RELEASED		WEG code: 14272436							
REL DT	15.04.2019	WMO	Jaragua do Sul	Product Engineering	SHEET	1 / 1			

125 HP 02 Poles 60Hz

A

