

# DATA SHEET



## Three Phase Induction Motor - Squirrel Cage

|   |  |   |                                |  |                  |           |
|---|--|---|--------------------------------|--|------------------|-----------|
| Customer : Dealers Industrial Equipment 800-469-3110  |  | Customer reference : 07536OT3V364TS-W40 |                                |  |                  |           |
| Product line : W40 NEMA Premium Efficiency Three-Phase  |  | Product code : 14270960                 | Catalog # : 07536OT3V364TS-W40 |  |                  |           |
| Frame : 364/5TS<br>Output : 75 HP (55 kW)<br>Poles : 2<br>Frequency : 60 Hz<br>Rated voltage : 200/400 V<br>Rated current : 195/97.5 A<br>L. R. Amperes : 1287/644 A<br>LRC : 6.6x(Code G)<br>No load current : 49.5/24.7 A<br>Rated speed : 3560 rpm<br>Slip : 1.11 %<br>Rated torque : 109 ft.lb<br>Locked rotor torque : 200 %<br>Breakdown torque : 250 %<br>Insulation class : F<br>Service factor : 1.25<br>Moment of inertia (J) : 6.40 sq.ft.lb<br>Design : B | Locked rotor time : 34s (cold) 19s (hot)<br>Temperature rise : 80 K<br>Duty cycle : Cont.(S1)<br>Ambient temperature : -20°C to +40°C<br>Altitude : 1000 m.a.s.l.<br>Protection degree : IP23<br>Cooling method : IC01 - ODP<br>Mounting : F-1<br>Rotation <sup>1</sup> : Both (CW and CCW)<br>Noise level <sup>2</sup> : 84.0 dB(A)<br>Starting method : Direct On Line<br>Approx. weight <sup>3</sup> : 716 lb |   |                                |  |                  |           |
| Output  | 25%  | 50%                                     | 75%                            | 100%   | Foundation loads |           |
| Efficiency (%)  | 91.0   | 91.7                                    | 93.0                           | 93.6   | Max. traction    | : 590 lb  |
| Power Factor  | 0.56   | 0.77                                    | 0.84                           | 0.87   | Max. compression | : 1306 lb |
|   |  | <u>Drive end</u>                        |                                | <u>Non drive end</u>   |                  |           |
| Bearing type  | :  | 6314 C3                                 |                                | 6212 Z C3  |                  |           |
| Sealing   | :  | Without Bearing Seal                    |                                | Without Bearing Seal   |                  |           |
| Lubrication interval  | :  | 14418 h                                 |                                | 20000 h  |                  |           |
| Lubricant amount  | :  | 27 g                                    |                                | 13 g   |                  |           |
| Lubricant type  | :  | Mobil Polyrex EM                        |                                |  |                  |           |
| Notes<br>downloaded from <a href="http://dealerselectric.com">http://dealerselectric.com</a>  |  |   |                                |  |                  |           |
| This revision replaces and cancel the previous one, which must be eliminated.<br>(1) Looking the motor from the shaft end.<br>(2) Measured at 1m and with tolerance of +3dB(A).<br>(3) Approximate weight subject to changes after manufacturing process.<br>(4) At 100% of full load.  |  |   |                                | These are average values based on tests with sinusoidal power supply, subject to the tolerances stipulated in NEMA MG-1. |                  |           |
| Rev.  | Changes Summary  |   |                                | Performed  | Checked          | Date      |
| Performed by  |  |   |                                |  |                  |           |
| Checked by  |  |   |                                |  | Page             | Revision  |
| Date  | 14/04/2019   |   |                                |  | 1 / 2            |           |

# LOAD PERFORMANCE CURVE



## Three Phase Induction Motor - Squirrel Cage

Customer : Dealers Industrial Equipment 800-469-3110  
 Customer reference : 07536OT3V364TS-W40

Product line : W40 NEMA Premium Efficiency Three-Phase      Product code : 14270960  
 Catalog # : 07536OT3V364TS-W40

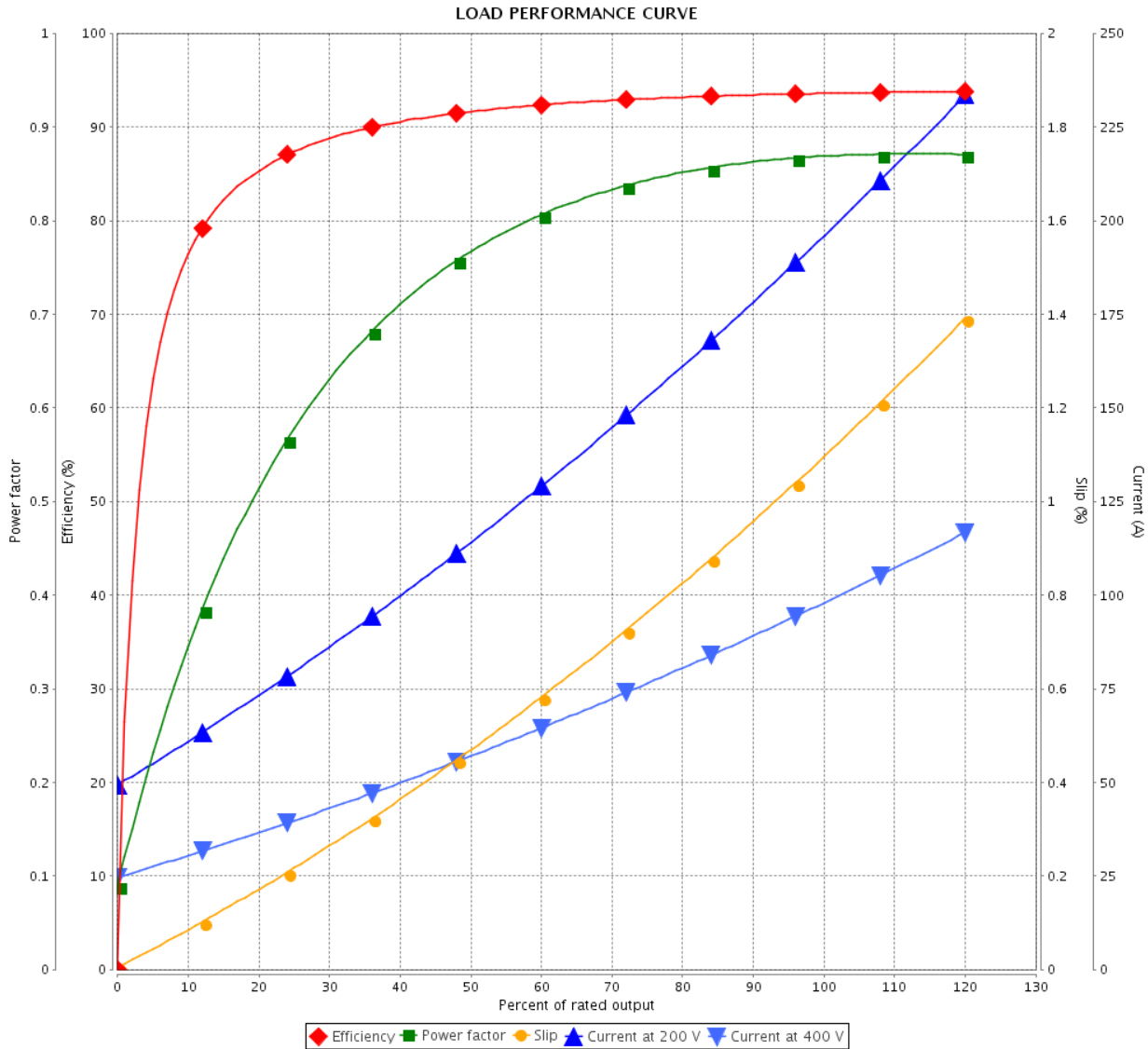

Performance : 200/400 V 60 Hz 2P

|                             |                                       |
|-----------------------------|---------------------------------------|
| Rated current : 195/97.5 A  | Moment of inertia (J) : 6.40 sq.ft.lb |
| LRC : 6.6                   | Duty cycle : Cont.(S1)                |
| Rated torque : 109 ft.lb    | Insulation class : F                  |
| Locked rotor torque : 200 % | Service factor : 1.25                 |
| Breakdown torque : 250 %    | Temperature rise : 80 K               |
| Rated speed : 3560 rpm      | Design : B                            |

| Rev.         | Changes Summary | Performed | Checked       | Date     |
|--------------|-----------------|-----------|---------------|----------|
|              |                 |           |               |          |
| Performed by |                 |           | Page<br>2 / 2 | Revision |
| Checked by   |                 |           |               |          |
| Date         | 14/04/2019      |           |               |          |

Dimensões em polegada  
Dimensions in inches

THIS IS AN UPDATED REVISION, THE  
PREVIOUS ONE MUST BE DISREGARDED.

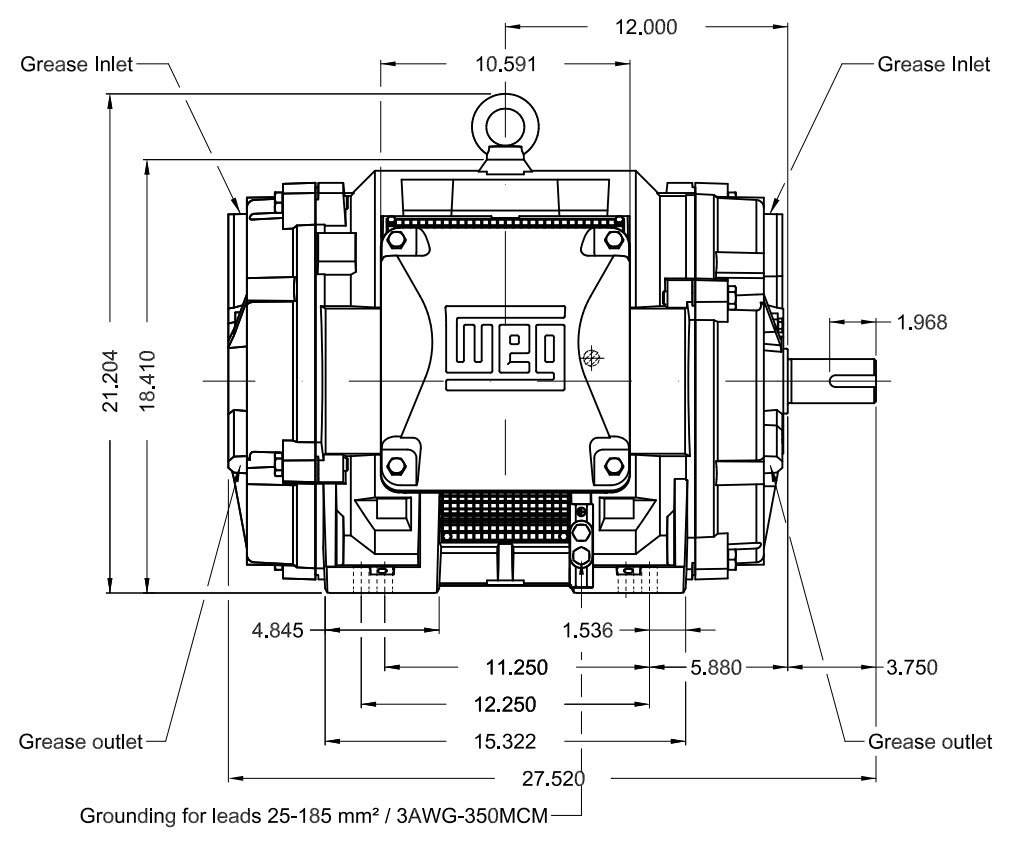
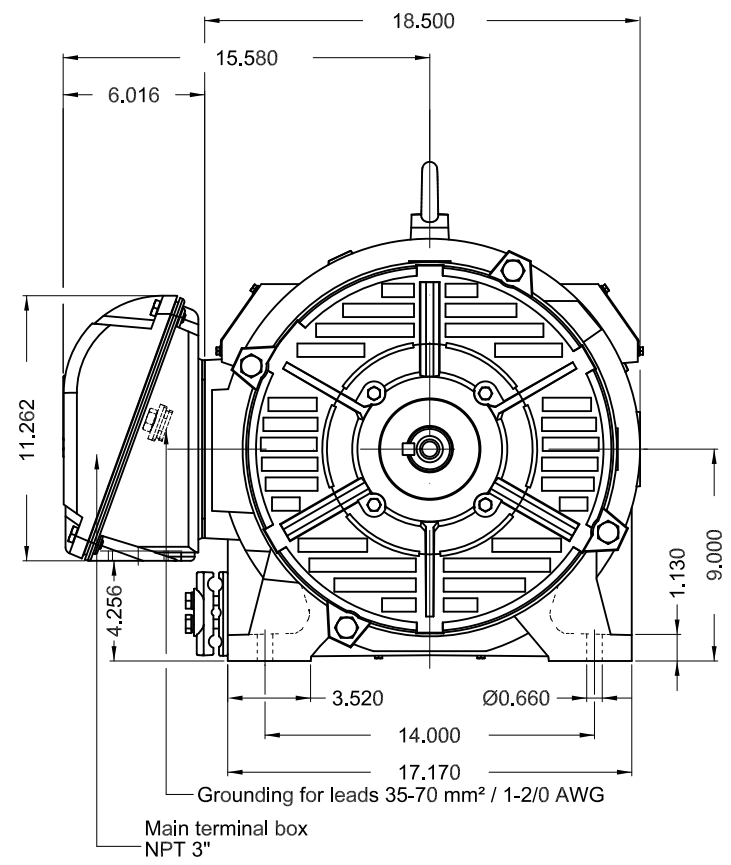

|                    |            |  |                |                     |          |         |
|--------------------|------------|--|----------------|---------------------|----------|---------|
| Color RAL 5009     |            |  |                |                     |          |         |
| Painting plan 203A |            |  |                |                     |          |         |
| Mounting B3R(D)    |            |  |                |                     |          |         |
|                    |            |  |                |                     | SCALE    | 1:8     |
| ECM                | LOC        | SUMMARY OF MODIFICATIONS               |                |                     | EXECUTED | CHECKED |
| EXECUTED           | USERADMIN  | THREE PHASE W40 MOTOR NEMA PREMIUM EFF |                |                     |          |         |
| CHECKED            |            | FRAME 364/5TS IP23 ODP                 |                |                     |          |         |
| RELEASED           |            | WEG code: 14270960                     |                |                     |          |         |
| REL DT             | 14.04.2019 | WMO                                    | Jaragua do Sul | Product Engineering | SHEET    | 1 / 1   |

75 HP 02 Poles 60Hz

A

