

# DATA SHEET



## Three Phase Induction Motor - Squirrel Cage

Customer : Dealers Industrial Equipment 800-469-3110  
 Customer reference : 07518OT3G365TS-W40

Product line : W40 NEMA Premium Efficiency Three-Phase      Product code : 14270944  
 Catalog # : 07518OT3G365TS-W40

Frame : 364/5TS	Locked rotor time : 25s (cold) 14s (hot)
Output : 75 HP (55 kW)	Temperature rise : 80 K
Poles : 4	Duty cycle : Cont.(S1)
Frequency : 60 Hz	Ambient temperature : -20°C to +40°C
Rated voltage : 460 V	Altitude : 1000 m.a.s.l.
Rated current : 85.5 A	Protection degree : IP23
L. R. Amperes : 581 A	Cooling method : IC01 - ODP
LRC : 6.8x(Code G)	Mounting : F-1
No load current : 30.5 A	Rotation <sup>1</sup> : Both (CW and CCW)
Rated speed : 1780 rpm	Noise level <sup>2</sup> : 69.0 dB(A)
Slip : 1.11 %	Starting method : Direct On Line
Rated torque : 218 ft.lb	Approx. weight <sup>3</sup> : 764 lb
Locked rotor torque : 220 %	
Breakdown torque : 260 %	
Insulation class : F	
Service factor : 1.25	
Moment of inertia (J) : 16.8 sq.ft.lb	
Design : B	

Output	25%	50%	75%	100%	Foundation loads
Efficiency (%)	94.4	94.5	95.0	95.0	Max. traction : 1655 lb
Power Factor	0.48	0.73	0.82	0.85	Max. compression : 2419 lb

		<u>Drive end</u>	<u>Non drive end</u>
Bearing type :		6314 C3	6212 Z C3
Sealing :		Without Bearing Seal	Without Bearing Seal
Lubrication interval :		20000 h	20000 h
Lubricant amount :		27 g	13 g
Lubricant type :		Mobil Polyrex EM	

Notes  
 downloaded from <http://dealerselectric.com>

This revision replaces and cancel the previous one, which must be eliminated.  
 (1) Looking the motor from the shaft end.  
 (2) Measured at 1m and with tolerance of +3dB(A).  
 (3) Approximate weight subject to changes after manufacturing process.  
 (4) At 100% of full load.

These are average values based on tests with sinusoidal power supply, subject to the tolerances stipulated in NEMA MG-1.

Rev.	Changes Summary	Performed	Checked	Date
Performed by		Page		Revision
Checked by		1 / 2		
Date	14/04/2019			

# LOAD PERFORMANCE CURVE



## Three Phase Induction Motor - Squirrel Cage

Customer : Dealers Industrial Equipment 800-469-3110  
 Customer reference : 07518OT3G365TS-W40

Product line : W40 NEMA Premium Efficiency Three-Phase      Product code : 14270944  
 Catalog # : 07518OT3G365TS-W40

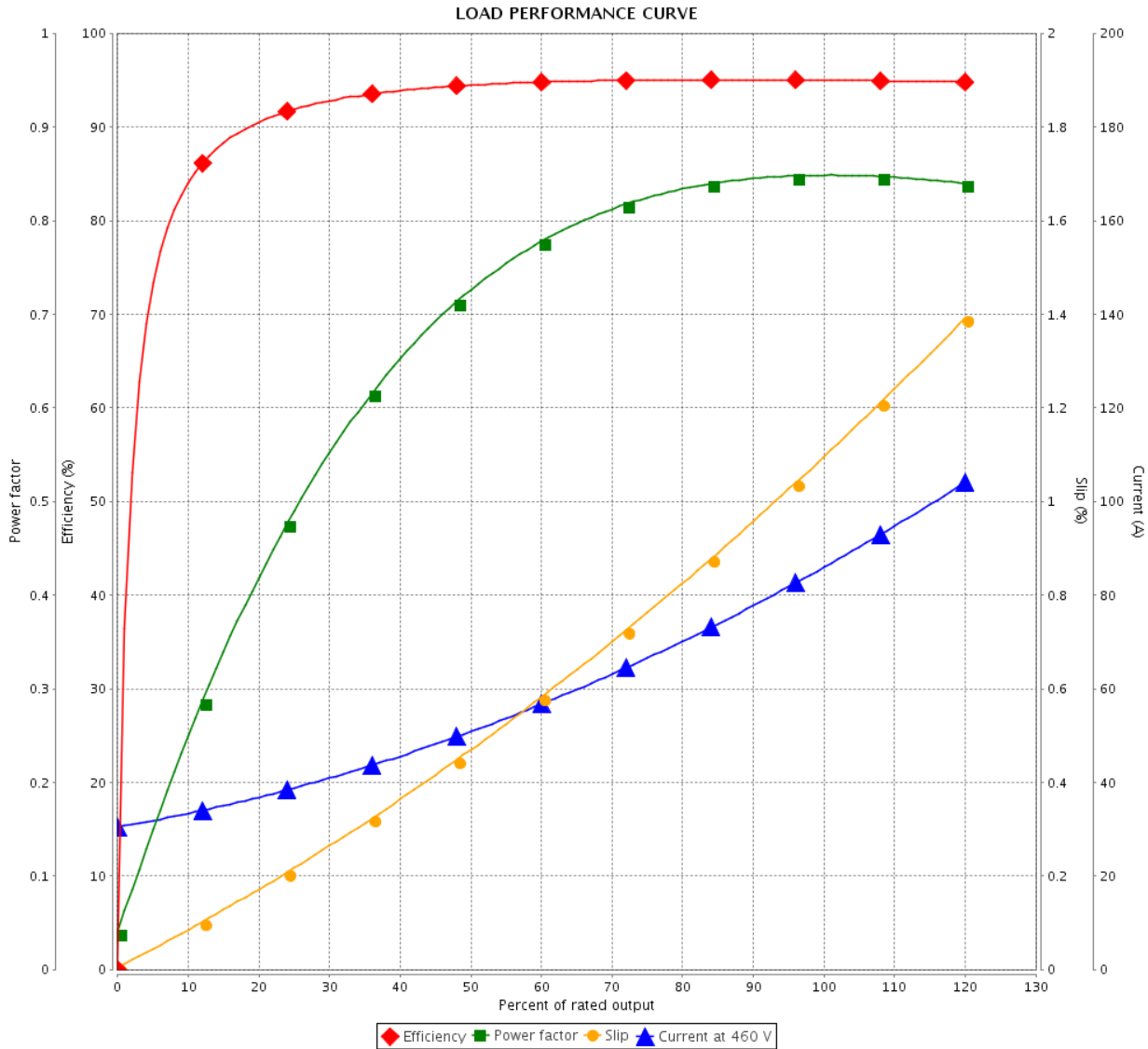

Performance : 460 V 60 Hz 4P

Rated current : 85.5 A	Moment of inertia (J) : 16.8 sq.ft.lb
LRC : 6.8	Duty cycle : Cont.(S1)
Rated torque : 218 ft.lb	Insulation class : F
Locked rotor torque : 220 %	Service factor : 1.25
Breakdown torque : 260 %	Temperature rise : 80 K
Rated speed : 1780 rpm	Design : B

Rev.	Changes Summary	Performed	Checked	Date
Performed by			Page 2 / 2	Revision
Checked by				
Date	14/04/2019			

Dimensões em polegada  
Dimensions in inches

THIS IS AN UPDATED REVISION, THE  
PREVIOUS ONE MUST BE DISREGARDED.

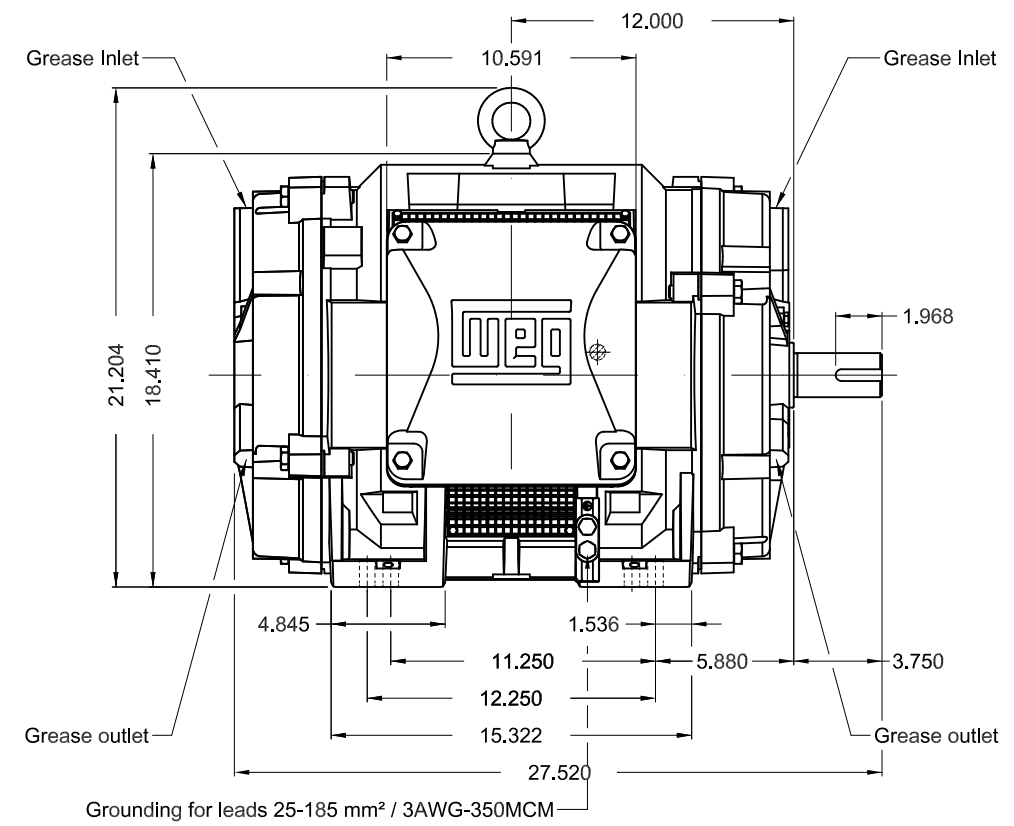
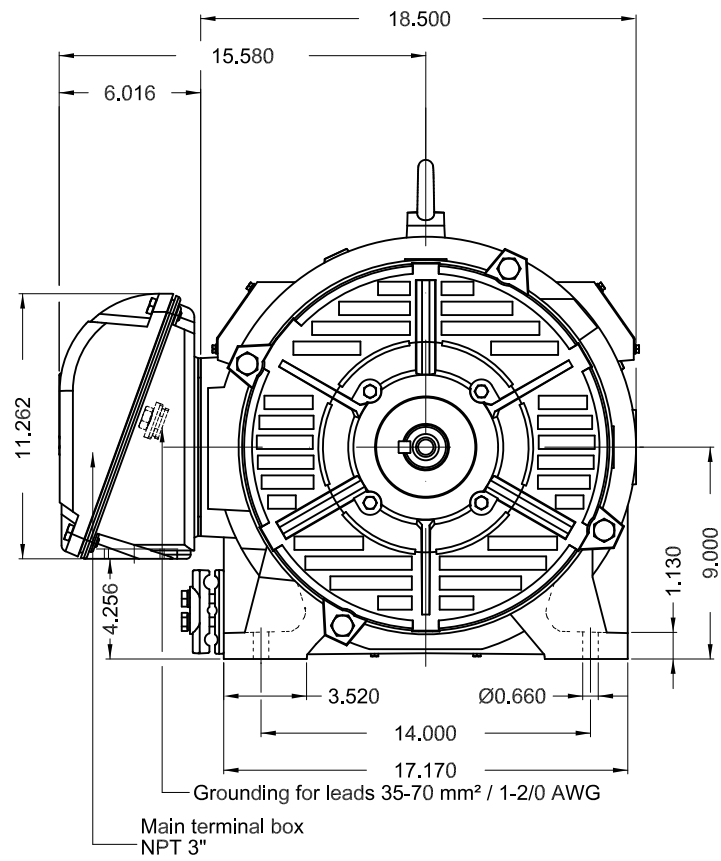

TS shaft end									
Color RAL 5009									
Painting plan 203A									
Mounting B3R(D)									
					SCALE	1:8			
ECM	LOC	SUMMARY OF MODIFICATIONS			EXECUTED	CHECKED	RELEASED	DATE	VER
EXECUTED	USERADMIN	THREE PHASE W40 MOTOR NEMA PREMIUM EFF							
CHECKED		FRAME 364/5TS IP23 ODP							
RELEASED		WEG code: 14270944							
REL DT	14.04.2019	WMO	Jaragua do Sul	Product Engineering	SHEET	1 / 1			

75 HP 04 Poles 60Hz

A



ZME A3