



# LOAD PERFORMANCE CURVE



## Three Phase Induction Motor - Squirrel Cage

Customer : Dealers Industrial Equipment 800-469-3110  
 Customer reference : 10018OT3E404T-W40

Product line : W40 NEMA Premium Efficiency Three-Phase      Product code : 14011071  
 Catalog # : 10018OT3E404T-W40

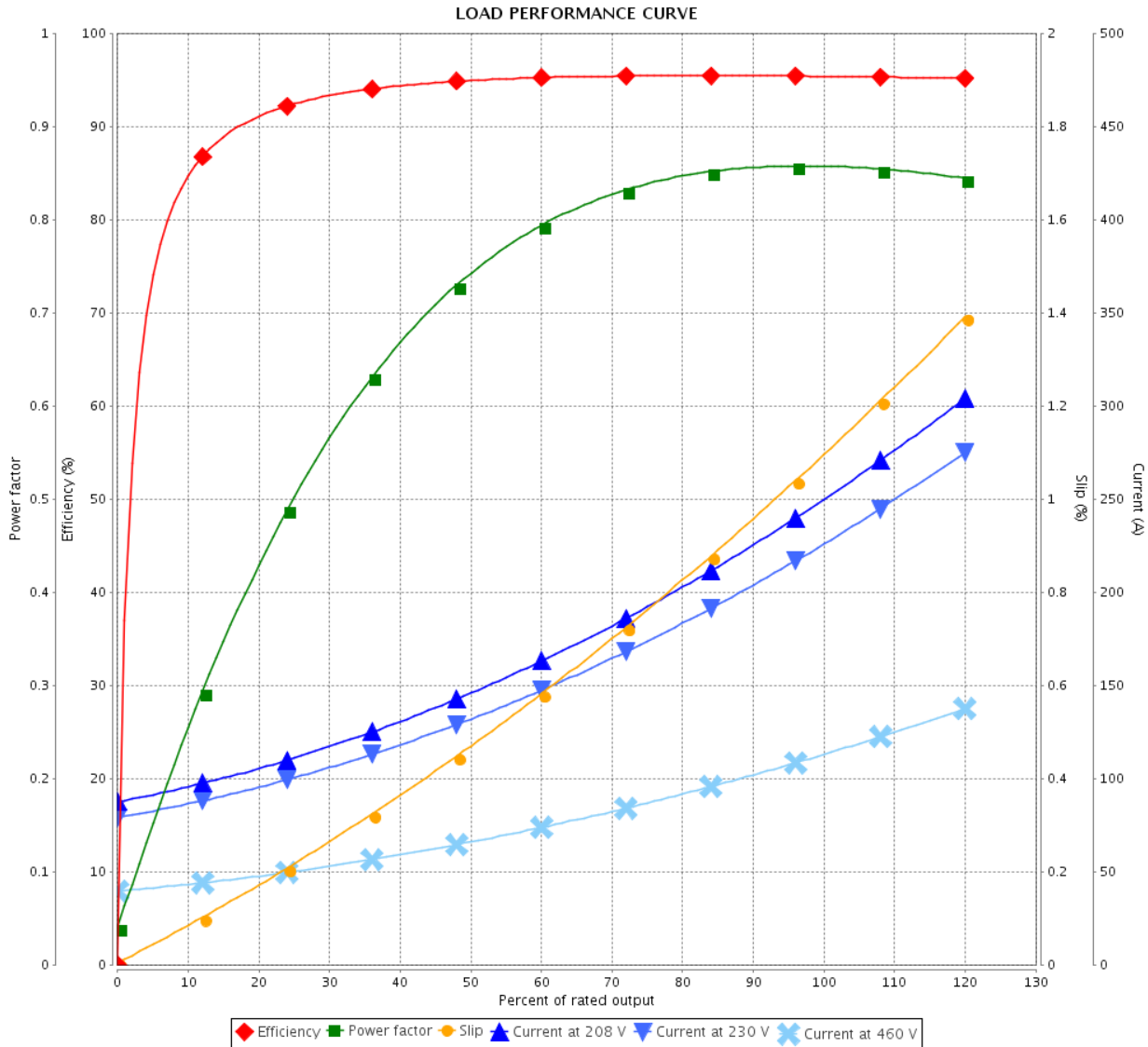

Performance : 208-230/460 V 60 Hz 4P

Rated current : 254-230/115 A	Moment of inertia (J) : 21.9 sq.ft.lb
LRC : 6.8	Duty cycle : Cont.(S1)
Rated torque : 291 ft.lb	Insulation class : F
Locked rotor torque : 200 %	Service factor : 1.25
Breakdown torque : 250 %	Temperature rise : 80 K
Rated speed : 1780 rpm	Design : B

Rev.	Changes Summary	Performed	Checked	Date
Performed by			Page	Revision
Checked by				
Date				

Dimensões em polegada  
Dimensions in inches

THIS IS AN UPDATED REVISION, THE  
PREVIOUS ONE MUST BE DISREGARDED.

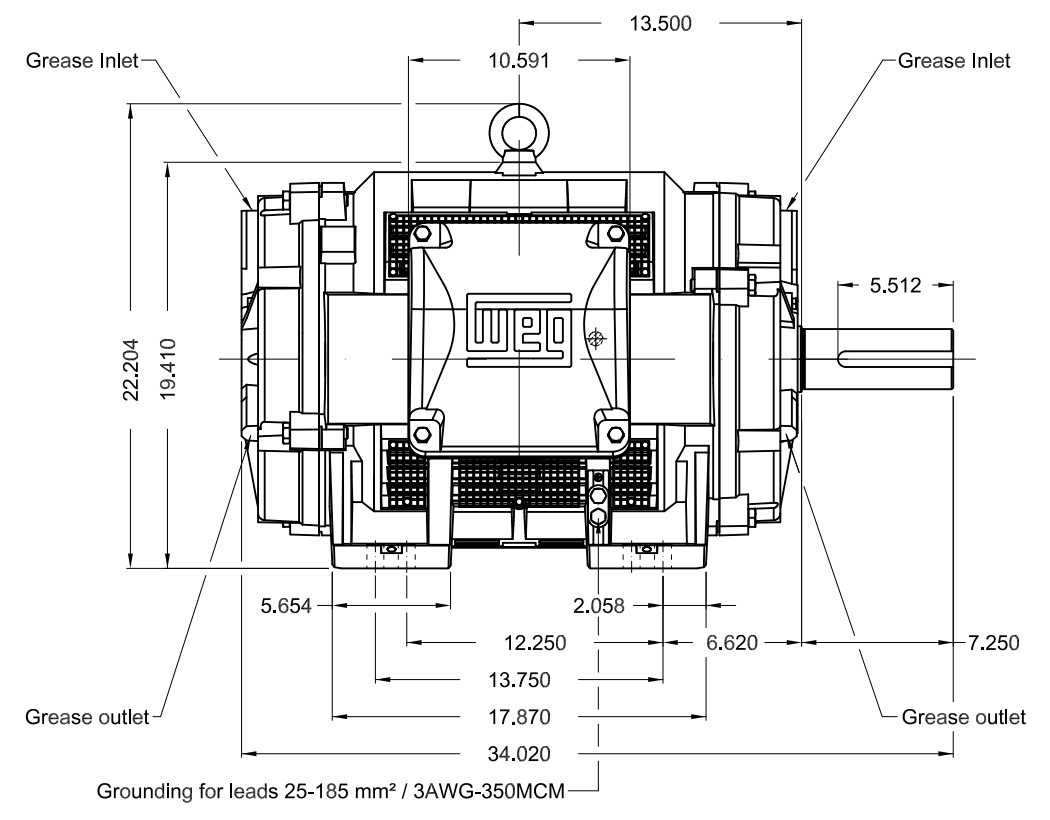
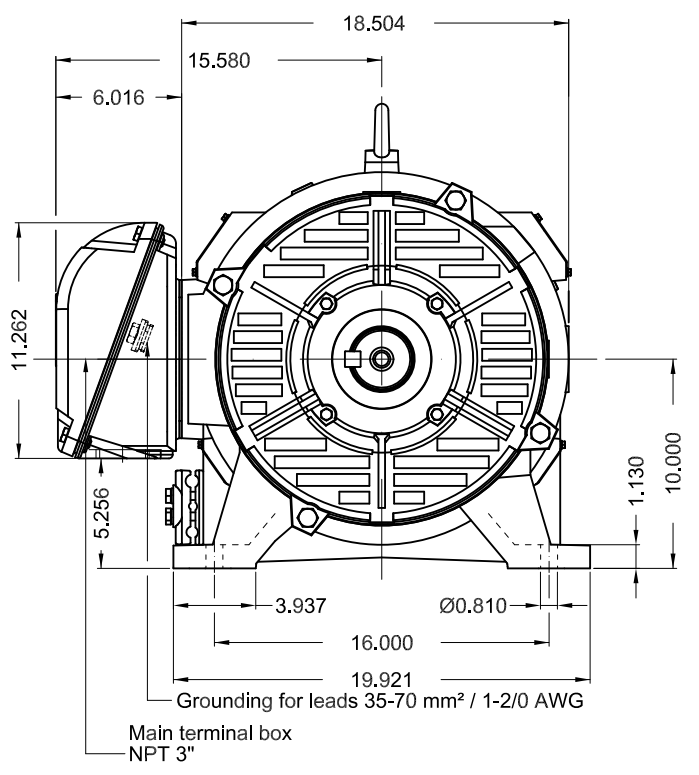

Color RAL 5009						
Painting plan 203A						
Mounting B3R(D)						
					SCALE	1:9
ECM	LOC	SUMMARY OF MODIFICATIONS			EXECUTED	CHECKED
EXECUTED	USERADMIN	THREE PHASE W40 MOTOR NEMA PREMIUM EFF				
CHECKED		FRAME 404/5T IP23 ODP				
RELEASED		WEG code: 14011071				
REL DT	15.04.2019	WMO	Jaragua do Sul	Product Engineering	SHEET	1 / 1

100 HP 04 Poles 60Hz

A



MODEL 100180T3E404T-W40  
MADE IN BRAZIL  
14011071

**WEG** **W40 NEMA**  
**CC029A Premium**  
*Inverter Duty Motor*

**CE** **UL** **US** **3PT9 LISTED**



IEC 60034-1

**SP**  
**US**  
Energy Verified

For 60Hz use on PWM, VT 1000:1, CT 2:1, 1.0SF

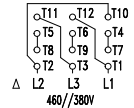
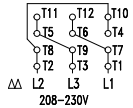
PH 3	FR 404/5T	HP(kW) 100.0(75.0)	Hz 60
V 230/460	A 230/115	RPM 1780	DES B
NEMA NOM EFF 95.4 %	INS. CL. F $\Delta$ T 80 K	IP23	
ENCL ODP	DUTY CONT.	AMB. 40°C	
CODE G	PF 0.86	SF 1.25	SFA 288/144
USABLE @208V 254 A	SF 1.15	SFA 292	
55kW 50Hz 380V 103A 1482RPM SF1.00 EFF 94.7% (IE3)	ALT 1000 m.a.s.l.		



-  → 6316-C3 (34g)
-  → 6212-Z-C3 (13g)

MOBIL POLYREX EM  
20000 h

ALT 1000 m.a.s.l. 956 Lbs