

PE213JM-7.5-4

CLOSE COUPLED PUMP MOTORS

NEMA PREMIUM EFFICIENCY

THREE PHASE, TOTALLY ENCLOSED FAN COOLED, JM FRAME

INVERTER DUTY 10:1 CT; 20:1 VT - NEMA MG1 PART 31

Factory Certified for T2B Class I, Division II, Groups A,B,C & D and Class II, Division II, Groups F & G

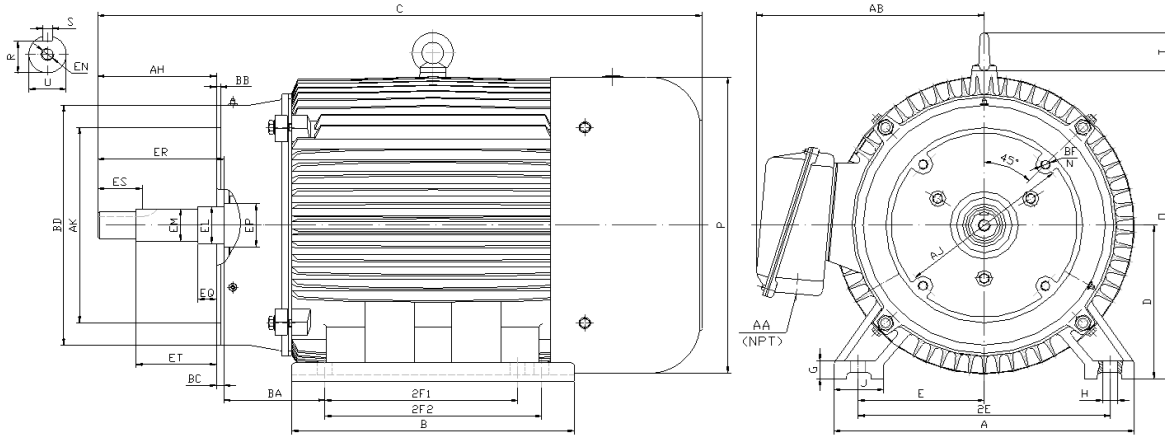

DIMENSIONS

HP	RPM	Frame	MOUNTING														
			A	B	C	D	G	H	J	E	2E	2F1	2F2	O	P	T	BA
7.5	1800	213JM	11.00	7.90	20.78	5.25	0.70	0.41	2.40	4.25	8.50	5.50	NA	11.20	11.60	1.90	4.25

FLANGE							Shaft Extension, Key Set											
AK	AJ	AH	BB	BC	BD	N*BF	U	R	S	EQ	ER	ES	ET	EP	EL	EM	EN	
8.500	7.25	4.281	0.312	0.25	9.00	4*1/2-13	0.8745	0.771	0.190	0.640	4.25	1.65	2.890	1.77	1.250	1.0000	3/8-16	
8.497		4.219	0.250				0.8740	0.756	0.188	0.610			2.860		1.248	0.9995		

Conduit Box		Bearings		Mount
AA	AB	DE	ODE	
1.00	9.00	6309-ZZ	6308-ZZ	F1

BEARING LUBRICATION: The bearings come lubricated with Mobil Polyrex EM Polyurea Grease.





PE213JM-7.5-4

CLOSE COUPLED PUMP MOTORS

NEMA PREMIUM EFFICIENCY

THREE PHASE, TOTALLY ENCLOSED FAN COOLED, JM FRAME

INVERTER DUTY 10:1 CT; 20:1 VT - NEMA MG1 PART 31







Factory Certified for T2B Class I, Division II, Groups A,B,C & D and Class II, Division II, Groups F & G

PERFORMANCE DATA

HP	RPM	Frame	Voltage	Frequency (Hz)	Full Load S.F.	Insulation Class	NEMA Design	Slip (%)	NEMA Code	Enclosure Type	IP Rating	Max. Ambient
7.5	1770	213JM	208-230/460	60	1.15	F	B	1.7	H	TEFC	55	40° C

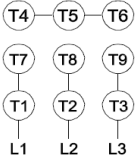
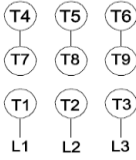
Amps (460V)		Efficiency (%)				Power Factor			Torque (ft-lb)			DE Bearing	ODE Bearing	Connection	Weight (lbs.)
FLA	LRA	100%	75%	50%	Min.	100%	75%	50%	FLT	LRT %	BDT %				
9.2	63.0	91.7	91.7	90.0	90.2	0.800	0.740	0.630	22.5	180	280	6309-ZZ	6308-ZZ	9 Lead 2Y/Y	162

NAME PLATE

 North American Electric, Inc.													CONNECTION DIAGRAMS 208-230V 		
INVERTER DUTY 20:1 VT; 10:1 CT										NEMA Premium					
CLOSE COUPLED PUMP MOTOR										460V 					
CAT NO: PE213JM-7.5-4			FRAME 213JM			PHASE 3									
HZ 60		S.F. 1.15		HZ 50		S.F. 1.0		ENCL TEFC					IP 55		
HP 7.5		RPM 1770		HP 7.5		RPM 1465		DUTY CONT					DES B		
VOLTS 208-230/460			VOLTS 190/380			AMB 40° C			INS F						
FLA 19.8 - 18.4 / 9.2		FLA 23/11.5			DE BEARING 6309-ZZ										
CODE H		P.F. 0.80		CODE G		P.F. 0.83		ODE BEARING 6308-ZZ							
EFF 91.7		MIN 90.2		EFF 89.7		MIN 88.2		LUB: Mobil Polyrex EM							
MOTOR WEIGHT 162 LBS		CONNECTION 9 Lead 2Y/Y			SER NO										
Specifically designed for use on industrial and commercial pumping units. Hernando, Mississippi													   CC 082A		

APPLICATIONS:

Specifically designed for use on industrial and commercial pumping units.