

PE213JM-7.5-2

CLOSE COUPLED PUMP MOTORS

NEMA PREMIUM EFFICIENCY

THREE PHASE, TOTALLY ENCLOSED FAN COOLED, JM FRAME

INVERTER DUTY 10:1 CT; 20:1 VT - NEMA MG1 PART 31

Factory Certified for T2B Class I, Division II, Groups A,B,C & D and Class II, Division II, Groups F & G

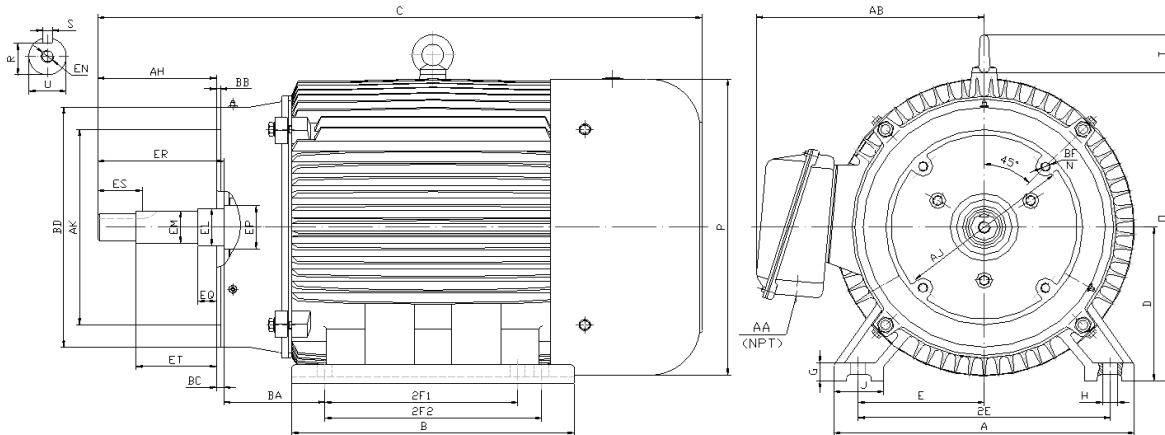

DIMENSIONS

HP	RPM	Frame	MOUNTING														
			A	B	C	D	G	H	J	E	2E	2F1	2F2	O	P	T	BA
7.5	3600	213JM	11.00	7.90	20.78	5.25	0.70	0.41	2.40	4.25	8.50	5.50	NA	10.50	10.20	1.90	4.25

FLANGE							Shaft Extension, Key Set										
AK	AJ	AH	BB	BC	BD	N*BF	U	R	S	EQ	ER	ES	ET	EP	EL	EM	EN
8.500	7.25	4.281	0.312	0.25	9.00	4*1/2-13	0.8745	0.771	0.190	0.640	4.25	1.65	2.890	1.77	1.250	1.0000	3/8-16
8.497		4.219	0.250				0.8740	0.756	0.188	0.610			2.860		1.248	0.9995	

Conduit Box		Bearings		Mount
AA	AB	DE	ODE	
1.00	8.30	6309-ZZ	6308-ZZ	F1

BEARING LUBRICATION: The bearings come lubricated with Mobil Polyrex EM Polyurea Grease.





PE213JM-7.5-2

CLOSE COUPLED PUMP MOTORS

NEMA PREMIUM EFFICIENCY

THREE PHASE, TOTALLY ENCLOSED FAN COOLED, JM FRAME

INVERTER DUTY 10:1 CT; 20:1 VT - NEMA MG1 PART 31







Factory Certified for T2B Class I, Division II, Groups A,B,C & D and Class II, Division II, Groups F & G

PERFORMANCE DATA

HP	RPM	Frame	Voltage	Frequency (Hz)	Full Load S.F.	Insulation Class	NEMA Design	Slip (%)	NEMA Code	Enclosure Type	IP Rating	Max. Ambient
7.5	3530	213JM	208-230/460	60	1.15	F	B	1.9	H	TEFC	55	40° C

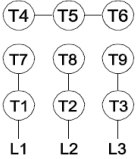
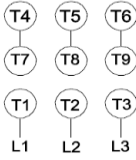
Amps (460V)		Efficiency (%)				Power Factor			Torque (ft-lb)			DE Bearing	ODE Bearing	Connection	Weight (lbs.)
FLA	LRA	100%	75%	50%	Min.	100%	75%	50%	FLT	LRT %	BDT %				
8.8	63.0	89.5	88.5	86.0	87.5	0.900	0.870	0.810	11.2	160	290	6309-ZZ	6308-ZZ	9 Lead 2Y/Y	156

NAME PLATE

 North American Electric, Inc.													CONNECTION DIAGRAMS 208-230V 		
INVERTER DUTY 20:1 VT; 10:1 CT										CLOSE COUPLED PUMP MOTOR					
CAT NO: PE213JM-7.5-2			FRAME 213JM			PHASE 3			460V 						
HZ 60	S.F. 1.15	HZ 50	S.F. 1.0	ENCL TEFC	IP 55										
HP 7.5	RPM 3530	HP 7.5	RPM 2920	DUTY CONT	DES B										
VOLTS 208-230/460		VOLTS 190/380		AMB 40° C		INS F									
FLA 18.8 - 17.6 / 8.8	FLA 21/10.5			DE BEARING 6309-ZZ											
CODE H	P.F. 0.90	CODE E	P.F. 0.92	ODE BEARING 6308-ZZ											
EFF 89.5	MIN 87.5	EFF 87.5	MIN 85.5	LUB: Mobil Polyrex EM											
MOTOR WEIGHT 156 LBS		CONNECTION 9 Lead 2Y/Y		SER NO											
Specifically designed for use on industrial and commercial pumping units. Hernando, Mississippi										   CC 082A					

APPLICATIONS:

Specifically designed for use on industrial and commercial pumping units.