

PE145JM-3-2

CLOSE COUPLED PUMP MOTORS

NEMA PREMIUM EFFICIENCY

THREE PHASE, TOTALLY ENCLOSED FAN COOLED, JM FRAME

INVERTER DUTY 10:1 CT; 20:1 VT - NEMA MG1 PART 31

Factory Certified for T2B Class I, Division II, Groups A,B,C & D and Class II, Division II, Groups F & G

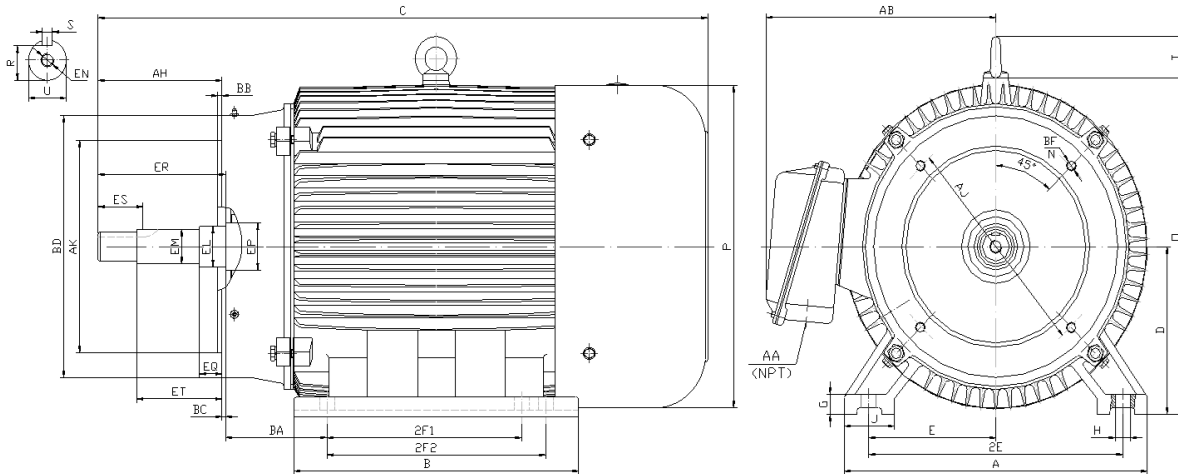

DIMENSIONS

HP	RPM	Frame	MOUNTING														
			A	B	C	D	G	H	J	E	2E	2F1	2F2	O	P	T	BA
3	3600	145JM	7.00	7.20	17.23	3.50	0.50	0.34	1.40	2.75	5.50	4.00	5.00	7.10	6.95	0.00	2.75

FLANGE							Shaft Extension, Key Set										
AK	AJ	AH	BB	BC	BD	N*BF	U	R	S	EQ	ER	ES	ET	EP	EL	EM	EN
4.500	5.88	4.281	0.156	0.12	6.62	4*3/8-16	0.8745	0.771	0.190	0.640	4.25	1.65	2.890	1.18	1.156	1.0000	3/8-16
4.497		4.219	0.125				0.8740	0.756	0.188	0.610			2.860		1.154	0.9995	

Conduit Box		Bearings		Mount
AA	AB	DE	ODE	
0.75	6.10	6206-ZZ	6205-ZZ	

BEARING LUBRICATION: The bearings come lubricated with Mobil Polyrex EM Polyurea Grease.





PE145JM-3-2

CLOSE COUPLED PUMP MOTORS

NEMA PREMIUM EFFICIENCY

THREE PHASE, TOTALLY ENCLOSED FAN COOLED, JM FRAME

INVERTER DUTY 10:1 CT; 20:1 VT - NEMA MG1 PART 31

Factory Certified for T2B Class I, Division II, Groups A,B,C & D and Class II, Division II, Groups F & G

PERFORMANCE DATA

HP	RPM	Frame	Voltage	Frequency (Hz)	Full Load S.F.	Insulation Class	NEMA Design	Slip (%)	NEMA Code	Enclosure Type	IP Rating	Max. Ambient
3	3480	145JM	208-230/460	60	1.15	F	B	3.3	K	TEFC	55	40° C

Amps (460V)		Efficiency (%)				Power Factor			Torque (ft-lb)			DE Bearing	ODE Bearing	Connection	Weight (lbs.)
FLA	LRA	100%	75%	50%	Min.	100%	75%	50%	FLT	LRT %	BDT %				
4.1	32.0	86.5	86.0	84.0	84.0	0.800	0.740	0.610	4.6	200	300	6206-ZZ	6205-ZZ	9 Lead 2Y/Y	60

NAME PLATE

													CONNECTION DIAGRAMS 208-230V 												
INVERTER DUTY 20:1 VT; 10:1 CT										CLOSE COUPLED PUMP MOTOR															
CAT NO:		PE145JM-3-2				FRAME		145JM		PHASE		3		460V 											
HZ		60		S.F.		1.15		HZ		50		S.F.					1.0		ENCL		TEFC		IP		55
HP		3		RPM		3480		HP		3		RPM		2840		DUTY		CONT		DES		B			
VOLTS		208-230/460				VOLTS		190/380		AMB		40° C		INS		F									
FLA		9 - 8.2 / 4.1				FLA		9.6/4.8		DE BEARING		6206-ZZ													
CODE		K		P.F.		0.80		CODE		F		P.F.		0.84		ODE BEARING		6205-ZZ							
EFF		86.5		MIN		84.0		EFF		84.5		MIN		82.0		LUB:		Mobil Polyrex EM							
MOTOR WEIGHT		60		LBS		CONNECTION		9 Lead 2Y/Y		SER NO															
Specifically designed for use on industrial and commercial pumping units. Hernando, Mississippi																CC 082A									

APPLICATIONS:

Specifically designed for use on industrial and commercial pumping units.