

PE145JM-2-2

CLOSE COUPLED PUMP MOTORS

NEMA PREMIUM EFFICIENCY

THREE PHASE, TOTALLY ENCLOSED FAN COOLED, JM FRAME

INVERTER DUTY 10:1 CT; 20:1 VT - NEMA MG1 PART 31

Factory Certified for T2B Class I, Division II, Groups A,B,C & D and Class II, Division II, Groups F & G

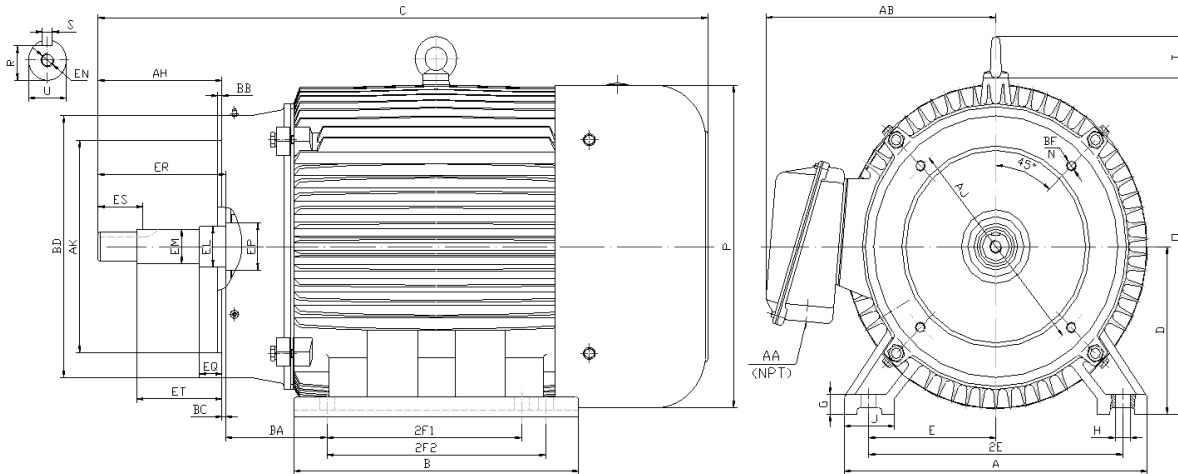

DIMENSIONS

HP	RPM	Frame	MOUNTING														
			A	B	C	D	G	H	J	E	2E	2F1	2F2	O	P	T	BA
2	3600	145JM	7.00	7.20	17.23	3.50	0.50	0.34	1.40	2.75	5.50	4.00	5.00	7.10	6.95	0.00	2.75

FLANGE							Shaft Extension, Key Set										
AK	AJ	AH	BB	BC	BD	N*BF	U	R	S	EQ	ER	ES	ET	EP	EL	EM	EN
4.500	5.88	4.281	0.156	0.12	6.62	4*3/8-16	0.8745	0.771	0.190	0.640	4.25	1.65	2.890	1.18	1.156	1.0000	3/8-16
4.497		4.219	0.125				0.8740	0.756	0.188	0.610			2.860		1.154	0.9995	

Conduit Box		Bearings		Mount
AA	AB	DE	ODE	
0.75	6.10	6206-ZZ	6205-ZZ	

BEARING LUBRICATION: The bearings come lubricated with Mobil Polyrex EM Polyurea Grease.





PE145JM-2-2

CLOSE COUPLED PUMP MOTORS

NEMA PREMIUM EFFICIENCY

THREE PHASE, TOTALLY ENCLOSED FAN COOLED, JM FRAME

INVERTER DUTY 10:1 CT; 20:1 VT - NEMA MG1 PART 31







Factory Certified for T2B Class I, Division II, Groups A,B,C & D and Class II, Division II, Groups F & G

PERFORMANCE DATA

HP	RPM	Frame	Voltage	Frequency (Hz)	Full Load S.F.	Insulation Class	NEMA Design	Slip (%)	NEMA Code	Enclosure Type	IP Rating	Max. Ambient
2	3510	145JM	208-230/460	60	1.15	F	B	2.5	L	TEFC	55	40° C

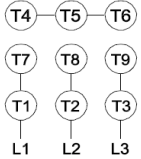
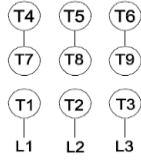
Amps (460V)		Efficiency (%)				Power Factor			Torque (ft-lb)			DE Bearing	ODE Bearing	Connection	Weight (lbs.)
FLA	LRA	100%	75%	50%	Min.	100%	75%	50%	FLT	LRT %	BDT %				
2.7	25.0	85.5	83.0	80.0	82.5	0.820	0.740	0.620	3.0	190	285	6206-ZZ	6205-ZZ	9 Lead 2Y/Y	49

NAME PLATE

 North American Electric, Inc.													CONNECTION DIAGRAMS 208-230V 			
INVERTER DUTY 20:1 VT; 10:1 CT					CLOSE COUPLED PUMP MOTOR											
CAT NO:		PE145JM-2-2			FRAME		145JM		PHASE		3		460V 			
HZ	60	S.F.	1.15	HZ	50	S.F.	1.0	ENCL	TEFC	IP	55					
HP	2	RPM	3510	HP	2	RPM	2870	DUTY	CONT	DES	B					
VOLTS		208-230/460			VOLTS		190/380		AMB		40° C		INS		F	
FLA	5.8 - 5.3 / 2.65			FLA		6.4/3.2		DE BEARING		6206-ZZ						
CODE	L	P.F.	0.82	CODE	F	P.F.	0.86	ODE BEARING		6205-ZZ						
EFF	85.5	MIN	82.5	EFF	83.5	MIN	80.5	LUB:		Mobil Polyrex EM						
MOTOR WEIGHT		49 LBS		CONNECTION		9 Lead 2Y/Y		SER NO								
Specifically designed for use on industrial and commercial pumping units. Hernando, Mississippi										  		CC 082A				

APPLICATIONS:

Specifically designed for use on industrial and commercial pumping units.