

PRODUCT INFORMATION PACKET

marathon[®]
Motors

Model No: 071T34FH5303
Catalog No: R406
1/2,3600,TEFC,71M,3/60/575
TEFC



Regal and Marathon are trademarks of Regal Beloit Corporation or one of its affiliated companies.

©2018 Regal Beloit Corporation, All Rights Reserved. MC017097E

REGAL[®]



Nameplate Specifications

Output HP	0.50 Hp	Output KW	0.37 kW
Frequency	60 Hz	Voltage	575 V
Current	0.66 A	Speed	3410 rpm
Service Factor	1.15	Phase	3
Efficiency	74 %	Duty	Continuous
Insulation Class	F	Design Code	B
KVA Code	J	Frame	D71
Enclosure	Totally Enclosed Fan Cooled	Overload Protector	No
Ambient Temperature	40 °C	Drive End Bearing Size	6203
Opp Drive End Bearing Size	6203	UL	Recognized
CSA	Y	CE	Y
IP Code	55		

Technical Specifications

Electrical Type	Squirrel Cage Induction Run	Starting Method	Across The Line
Poles	2	Rotation	Reversible
Mounting	B3	Motor Orientation	Horizontal
Drive End Bearing	Ball	Opp Drive End Bearing	Ball
Frame Material	Aluminum	Shaft Type	IEC
Overall Length	9.44 in	Shaft Diameter	0.555 in
Shaft Extension	1.18 in	Assembly/Box Mounting	F3
Outline Drawing	16986000ME	Connection Diagram	00546801ME

This is an uncontrolled document once printed or downloaded and is subject to change without notice. Date Created: 06/29/2018

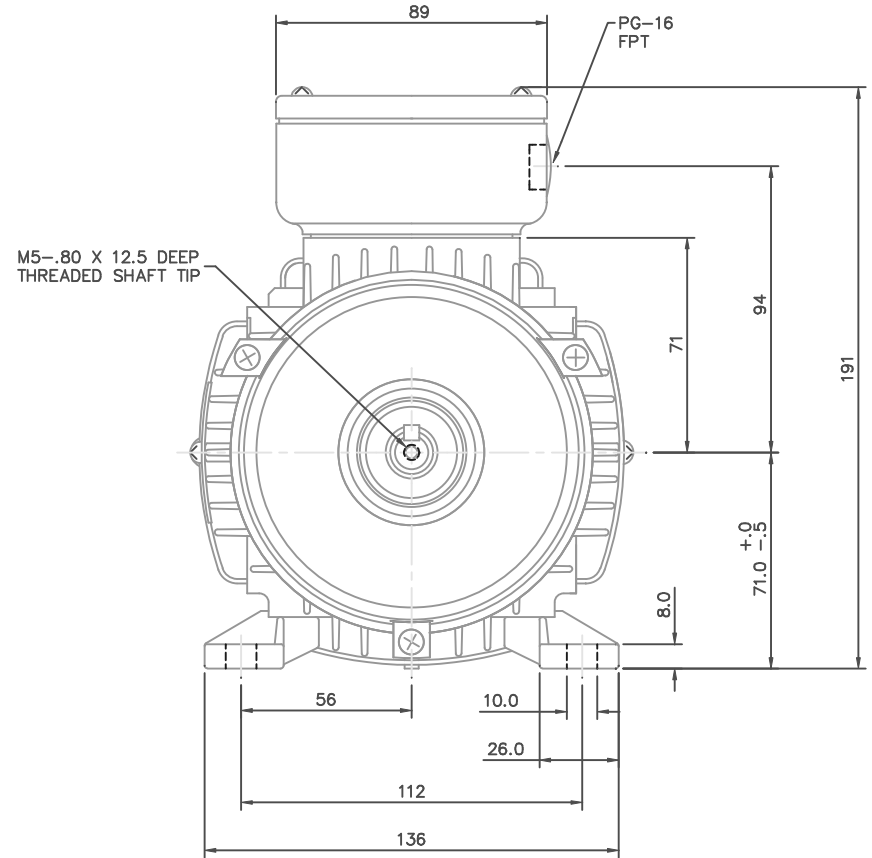
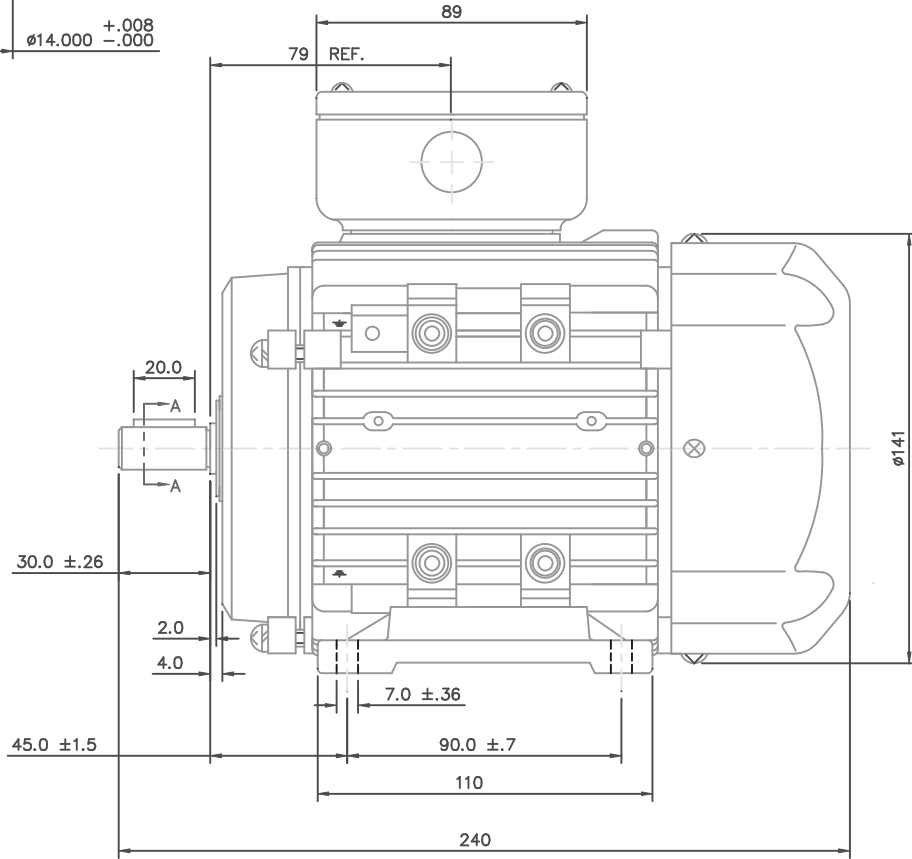
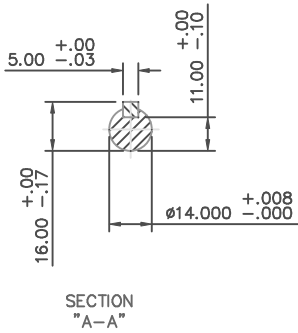

NO.		REVISION	BY & DATE	CHK	ANG	±7'30"	FINISH	PREV				
THIS DRAWING IN DESIGN AND DETAIL IS OUR PROPERTY AND MUST NOT BE USED EXCEPT IN CONNECTION WITH OUR WORK. ALL RIGHTS OF DESIGN AND INVENTION ARE RESERVED. THIS IS AN ELECTRONICALLY GENERATED DOCUMENT - DO NOT SCALE THIS PRINT.							RFP	CAD FILE	16986000ME	SIZE	DRAWING NO.	REV.
							DIST		B	169860-00ME		

TOLERANCES UNLESS SPECIFIED		DRAWN	
DEC.	METRIC	ADS	01/18/02
.X	±2.5	CHK	
.XX	±.76	APPD	
.XXX	±.127	SCALE	1=1.6
.XXXX	±.0127	REF	OSVC-300-553
		FMF	
		PREV	

MARATHON ELECTRIC		TITLE	
		METRIC MOTOR OUTLINE, IMB3 IEC-71 FRAME RIGID	
		MAT'L	
		ALUMINUM	

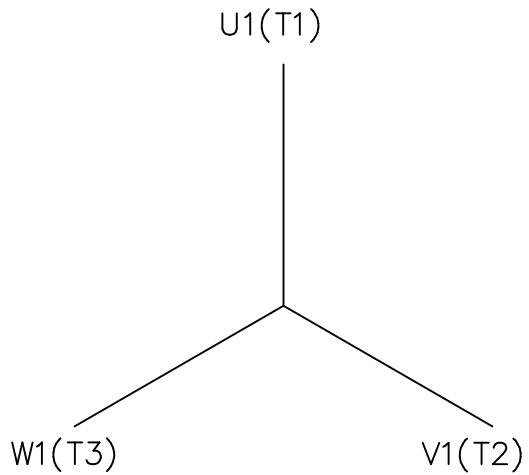

IEC MARKINGS

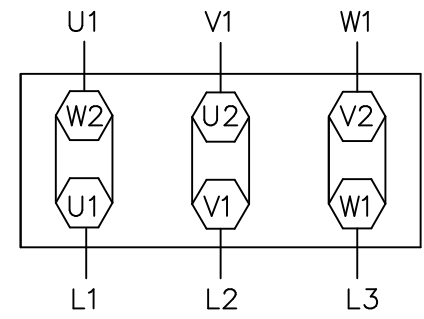

NEMA MARKINGS

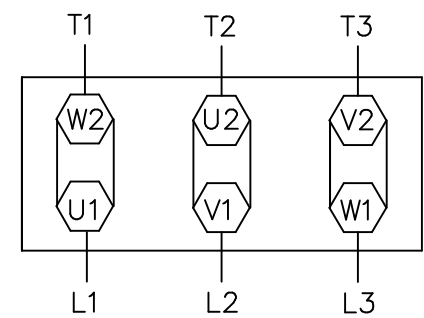

TO REVERSE ROTATION
INTERCHANGE ANY TWO
LINE LEADS

		TOLERANCES UNLESS SPECIFIED	
		DEC.	INCHES
		.X	±.1
		.XX	±.01
		.XXX	±.005
		.XXXX	±.0005
NO.	REVISION	BY & DATE	CHK ANG ±1/2'



TITLE: EXTERNAL WIRING DIAGRAM
TYPE "T" W/O PROT W/TERM. BLOCK

MAT'L:

FINISH:

DRAWN	JGO 3/10/04
CHK	
APPD	
SCALE	3=4
REF	
FMF	
PREV	

THIS DRAWING IN DESIGN AND DETAIL IS OUR PROPERTY AND MUST NOT BE USED EXCEPT IN CONNECTION WITH OUR WORK ALL RIGHTS OF DESIGN AND INVENTION ARE RESERVED THIS IS AN ELECTRONICALLY GENERATED DOCUMENT - DO NOT SCALE THIS PRINT		RFP	CAD FILE	00546801ME	SIZE	DRAWING NO.	REV.
		DIST			A	005468-01ME	

