

# PRODUCT INFORMATION PACKET



Model No: CM34D25NZ47C

Catalog No: M1135056.00

...10:1.250RPM.10LBIN.1/12HP.34...DC GEARMOTORS SUB-FHP.180V.DC.TENV  
Right Angle



Regal and Leeson are trademarks of Regal Beloit Corporation or one of its affiliated companies.

©2018 Regal Beloit Corporation, All Rights Reserved. MC017097E





### Nameplate Specifications

Output HP	0.08 Hp	Output KW	0.06 kW
Voltage	180 V	Current	0.53 A
Speed	250 rpm	Service Factor	1
Efficiency	22.3 %	Duty	Continuous
Insulation Class	H	Frame	34
Enclosure	Totally Enclosed Non Ventilated	Overload Protector	No
Ambient Temperature	40 °C	Drive End Bearing Size	6201
Opp Drive End Bearing Size	608	UL	Recognized
CSA	Y	CE	Y

### Technical Specifications

Rotation	Reversible	Mounting	Special
Shaft Type	Right Angle	Overall Length	9.64 in
Frame Length	2.81 in	Shaft Diameter	0.625 in
Shaft Extension	1.8 in		
Outline Drawing	M1030443-M1135056	Connection Diagram	M100512401

This is an uncontrolled document once printed or downloaded and is subject to change without notice. Date Created: 10/15/2018

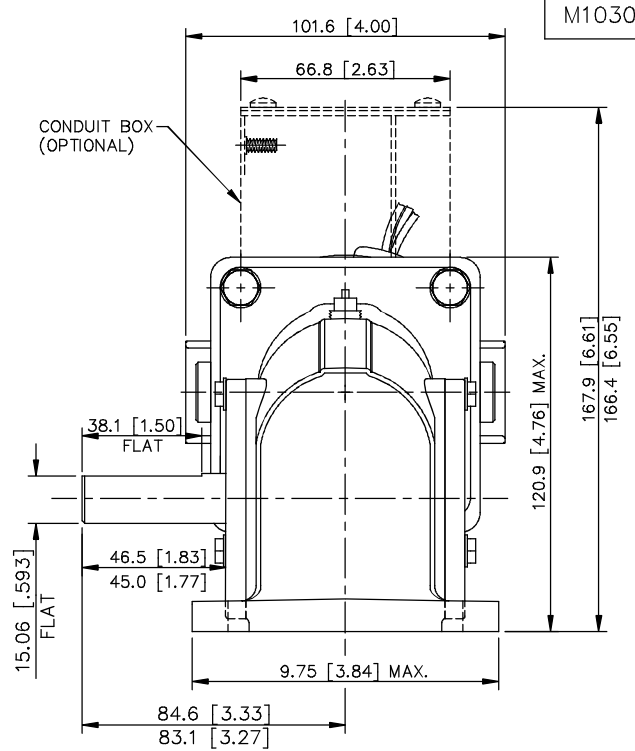
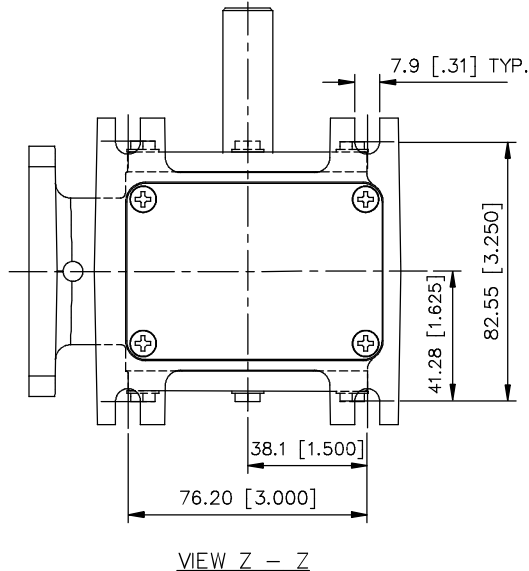
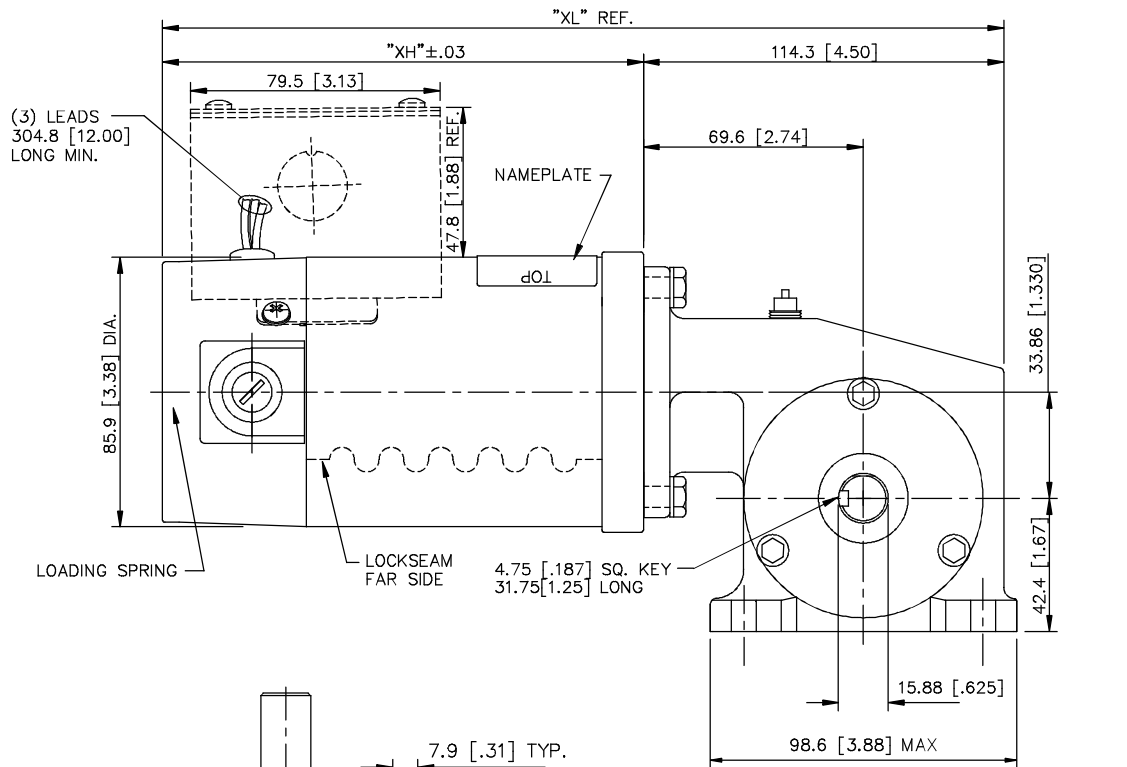

M1030443.00

CATALOG NUMBER	SPEED RANGE RPM	FULL LOAD TORQUE LB.-IN.	INPUT HP	OVERHUNG LOAD LBS.	GEARMOTOR TYPE & FRAME	RATIO TO 1	"XH"	"XL"
M1135053.00	42-7	30	1/12	235	13F60-34A	60	130.6 [5.14]	244.9 [9.64]
M1135054.00	62-1	35	1/12	235	13F40-34A	40	130.6 [5.14]	244.9 [9.64]
M1135055.00	125-2.1	18	1/12	235	13F20-34A	20	130.6 [5.14]	244.9 [9.64]
M1135056.00	250-4	12	1/12	235	13F20-34A	10	130.6 [5.14]	244.9 [9.64]
M1135057.00	500-8	7	1/12	235	13F20-34A	5	130.6 [5.14]	244.9 [9.64]
M1135058.00	62-1	70	1/8	235	13F40-34C	40	156.0 [6.14]	270.3 [10.64]
M1135059.00	125-2.1	45	1/8	235	13F20-34C	20	156.0 [6.14]	270.3 [10.64]
M1135060.00	250-4	25	1/8	235	13F10-34C	10	156.0 [6.14]	270.3 [10.64]
M1135061.00	500-8	13	1/8	235	13F05-34C	5	156.0 [6.14]	270.3 [10.64]
M1135062.00	62-1	135	1/4	235	13F40-34G	40	206.8 [8.14]	321.1 [12.64]
M1135063.00	83-1.4	125	1/4	235	13F30-34G	30	206.8 [8.14]	321.1 [12.64]
M1135064.00	125-2.1	90	1/4	235	13F20-34G	20	206.8 [8.14]	321.1 [12.64]
M1135065.00	250-4	50	1/4	235	13F10-34G	10	206.8 [8.14]	321.1 [12.64]
M1135066.00	500-8	30	1/4	235	13F05-34G	5	206.8 [8.14]	321.1 [12.64]

07	CHANGED TO DIE CAST GEARBOX PER ECN 06-3023.	RPB 7/11/06	BC	TOLERANCES UNLESS SPECIFIED		<b>OUTLINE 34 FRAME DC 13 SERIES 180 V. GEARBOX</b>	DRAWN	SPV 05/11/95		
06	CORRECTED VIEW "Z-Z" PER OTHER TWO VIEWS PER ECR 73469	BPW 03/14/02	SAD	DEC. INCHES			CHK	APPD	DWF 05/11/95	
05	CORRECTED LENGTH OF KEY: 1.25 WAS 1.00	IPG 11/15/00	.XX	±.03	TITLE	SCALE	5=8			
04	DIM 1.50 WAS 1.25	SAD 05/04/98	.XXX	±.005	MAT'L	REF	M1030350			
03	1.83/1.77 WAS 1.53/1.47, 3.33/3.27 WAS	SAD 05/04/98	.XXXX	±.0005	FINISH	FMF	M1135053.00			
NO.	REVISION	BY & DATE	CHK	ANG	±1/2"	LEESON	PREV			
THIS DRAWING IN DESIGN AND DETAIL IS OUR PROPERTY AND MUST NOT BE USED EXCEPT IN CONNECTION WITH OUR WORK ALL RIGHTS OF DESIGN AND INVENTION ARE RESERVED THIS IS AN ELECTRONICALLY GENERATED DOCUMENT - DO NOT SCALE THIS PRINT					RFP	CAD FILE	M1030443	SIZE	DRAWING NO.	REV.
					DIST			B	M1030443.00	07

D.C. MOTORS



EXTERNAL CONNECTIONS FOR CW ROTATION  
VIEWING LEAD END OF MOTOR WITH RED LEAD  
POSITIVE AND BLACK LEAD NEGATIVE (-)  
FOR CCW ROTATION REVERSE POLARITY

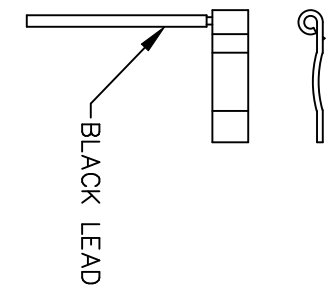

07	CORRECTED "N" & "S", ECR 80000 (PER BC)	VS	8/14/02	BC	TOLERANCES UNLESS SPECIFIED		<b>LEESON</b>	ELECTRIC MOTORS GEARMOTORS AND DRIVES	DRAWN	SPV 12/10/91
06	REMOVED GROUND HOLE	TMZ	3/16/95	DEC.	INCHES				CHK	DWF 5/20/92
05	REVERSE ROTATION WAS CW	SPV	6/3/94	.X	±.1		TITLE	CONNECTION DIAGRAM	APPD	
04	CHANGED ROTATION FROM CCW TO CW	MJS	3/9/93	.XX	±.01				SCALE	1=1
03	REVISED ROTATION NOTE	DWF	1/6/93	.XXX	±.005		MAT'L.		REF	
02	ADDED GREEN LEAD	DWF	8/1/92	.XXXX	±.0005				FINISH	
NO.	REVISION	BY & DATE	CHK	ANG	±1/2"				PREV	
THIS DRAWING IN DESIGN AND DETAIL IS OUR PROPERTY AND MUST NOT BE USED EXCEPT IN CONNECTION WITH OUR WORK ALL RIGHTS OF DESIGN AND INVENTION ARE RESERVED THIS IS AN ELECTRONICALLY GENERATED DOCUMENT - DO NOT SCALE THIS PRINT				RFP	CAD FILE	M100512401	SIZE	DRAWING NO.	REV.	
				DIST			A	M1005124.01	07	