

# PRODUCT INFORMATION PACKET



Model No: CM31P17NZ16A

Catalog No: M1125083.00

10...20:1.85RPM.24LBIN..06HP.31...AC GEARMOTORS SUB-  
FHP.115/230V.1PH.60/50HZ.TENV.CM31P17NZ16A

Right Angle



Regal and Leeson are trademarks of Regal Beloit Corporation or one of its affiliated companies.

©2018 Regal Beloit Corporation, All Rights Reserved. MC017097E





### Nameplate Specifications

Output HP	<b>0.06 Hp</b>	Output KW	<b>0.04 kW</b>
Frequency	<b>60 Hz</b>	Voltage	<b>115 V</b>
Current	<b>0.90/0.45 A</b>	Speed	<b>85 rpm</b>
Service Factor	<b>1</b>	Phase	<b>1</b>
Duty	<b>Continuous</b>	Insulation Class	<b>F</b>
KVA Code	<b>C</b>	Frame	<b>31</b>
Enclosure	<b>Totally Enclosed Non Ventilated</b>	Overload Protector	<b>No</b>
Ambient Temperature	<b>40 °C</b>	Drive End Bearing Size	<b>6201</b>
Opp Drive End Bearing Size	<b>608</b>	UL	<b>Recognized</b>
CSA	<b>Y</b>	CE	<b>Y</b>

### Technical Specifications

Rotation	<b>Reversible</b>	Mounting	<b>Special</b>
Shaft Type	<b>Right Angle</b>	Overall Length	<b>8.94 in</b>
Frame Length	<b>4.75 in</b>	Shaft Diameter	<b>0.500 in</b>
Shaft Extension	<b>1.3 in</b>		
Outline Drawing	<b>M1030420-M1125083</b>	Connection Diagram	<b>M1005040.02</b>

**This is an uncontrolled document once printed or downloaded and is subject to change without notice. Date Created: 10/15/2018**

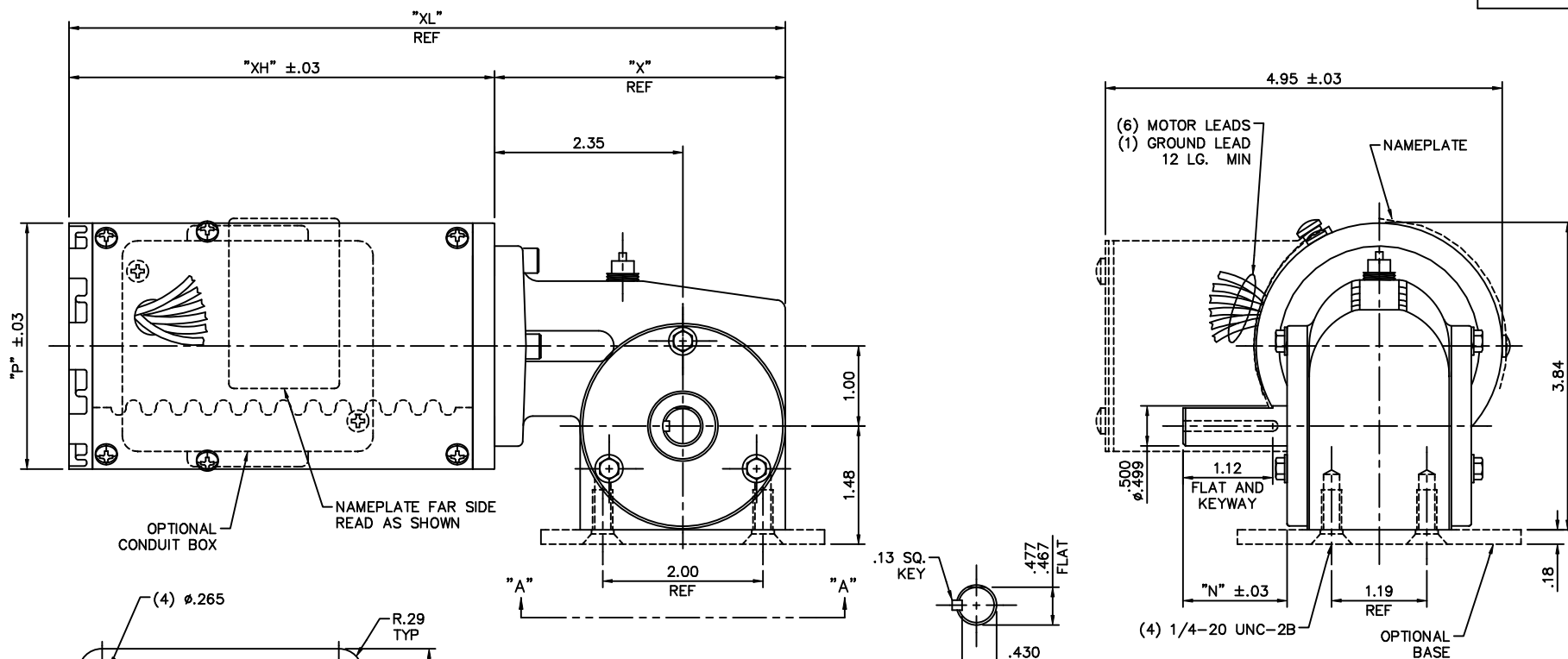

SHAFT DETAIL

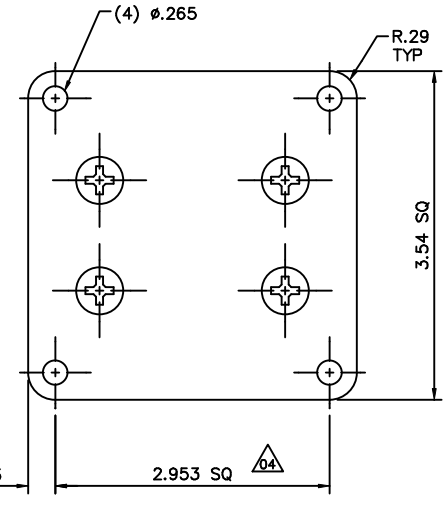

VIEW "A-A"  
(OPTIONAL BASE)

CATALOG NUMBER	SPEED RANGE RPM	FULL LOAD TORQUE LB.-IN.	INPUT HP	OVERHUNG LOAD LBS.	RATIO TO 1	"P"	"X"	"XH"	"XL"	"N"
M1125084.00	173	14	1/15	185	10	3.07	3.63	5.31	8.94	1.30
M1125083.00	85	24	1/15	185	20	3.07	3.63	5.31	8.94	1.30
M1125082.00	58	40	1/15	185	30	3.07	3.63	5.31	8.94	1.30
M1125081.00	43	34	1/15	185	40	3.07	3.63	5.31	8.94	1.30
M1125080.00	28	37	1/15	185	60	3.07	3.63	5.31	8.94	1.30

06	ADDED "N" DIM TO CHART	RLW 7/8/05	TOLERANCES UNLESS SPECIFIED		ELECTRIC MOTORS GEARMOTORS AND DRIVES TITLE OUTLINE DRAWING RIGHT ANGLE GEARMOTOR	DRAWN	TMZ 02/04/95		
05	"D" DIM. WAS 1.30 & UPDATE CHART PER ECO 05-1249	LST 6/24/05	DEC. INCHES			CHK			
04	BASE DIM, 2.953 SQ WAS 3.54, REV'D TO MATCH PART	BJB 05/10/05	.X ±.1	APPD					
03	DIM 1.12 WAS .93	SAD 05/06/98	.XX ±.03	SCALE	3=4				
02	GEAR SYSTEMS GEARBOX WAS HUB CITY GEARBOX	SAD 03/31/98	.XXX ±.005	REF	M1125084.00				
01	UPDATED ITEM BLOCK	SPV 04/26/95	.XXXX ±.0005	FMF	PR940044				
NO.	REVISION	BY & DATE	CHK ANG ±1/2"	FINISH	PREV				
THIS DRAWING IN DESIGN AND DETAIL IS OUR PROPERTY AND MUST NOT BE USED EXCEPT IN CONNECTION WITH OUR WORK ALL RIGHTS OF DESIGN AND INVENTION ARE RESERVED THIS IS AN ELECTRONICALLY GENERATED DOCUMENT - DO NOT SCALE THIS PRINT				RFP	CAD FILE	M1030420	SIZE	DRAWING NO.	REV.
				DIST	B	M1030420.00	06		

M1005040.02

COLORED LEADS

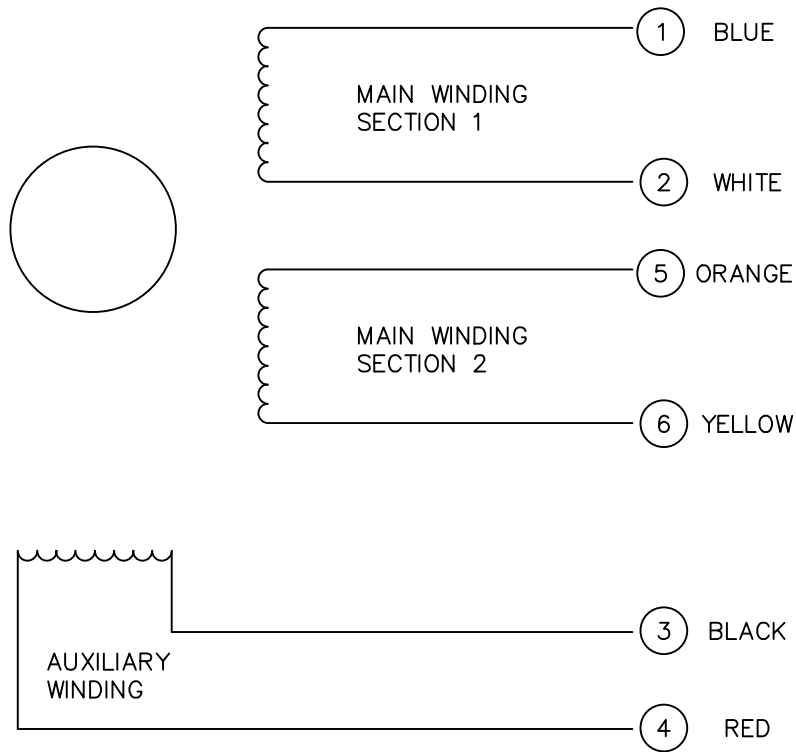

HIGH VOLTAGE CONNECTIONS

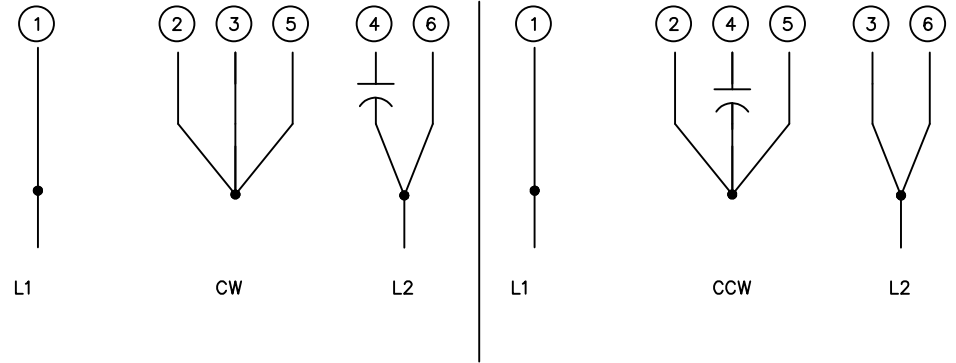

ROTATION VIEWING LEAD END OF MOTOR

LOW VOLTAGE CONNECTIONS

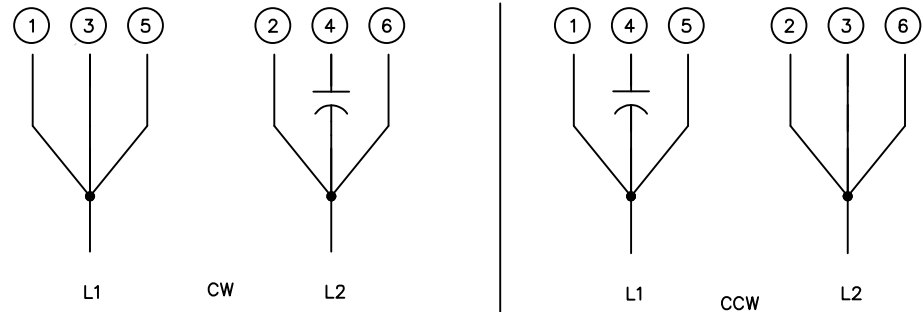

ROTATION VIEWING LEAD END OF MOTOR

TOLERANCES UNLESS OTHERWISE SPECIFIED

DECIMALS

.00 ± .01

.000 ± .005

.0000 ± .0005

FRACTIONS ± 1/64

ANGLES ± 1/2°

INCH/MM

**LEESON** ELECTRIC CORPORATION

DRAWN DK

CH'K'D. 10/3/91

APPR. 10/3/91

SCALE NONE

REF.

FMF PR91376

TITLE EXTERNAL WIRING DIAGRAM  
DUAL VOLTAGE DUAL ROTATION

MAT'L.

FINISH

LECO CORP.

SIZE

A

DRAWING NO.

M1005040.02

THIS DRAWING IN DESIGN AND DETAIL IS OUR PROPERTY AND MUST NOT BE USED EXCEPT IN CONNECTION WITH OUR WORK ALL RIGHTS OF DESIGN AND INVENTION ARE RESERVED

NO.	REVISION	BY	DATE
02	REDRAWN ON CAD	AJR	6/28/99
01	REMOVED CAP FROM LEFT DIAGRAM	DD	9/16/95