

# PRODUCT INFORMATION PACKET



Model No: C4D17VK3F

Catalog No: 108228.00

3/4HP.1750RPM.S56C.TENV.90V.CONT.40C.1.0SF.RIGID C.WASHGUARD.C4D17VK3F  
White Epoxy



Regal and Leeson are trademarks of Regal Beloit Corporation or one of its affiliated companies.

©2018 Regal Beloit Corporation, All Rights Reserved. MC017097E





### Nameplate Specifications

|                            |                                 |                        |            |
|----------------------------|---------------------------------|------------------------|------------|
| Output HP                  | 0.75 Hp                         | Output KW              | 0.56 kW    |
| Voltage                    | 90 V                            | Current                | 7.0 A      |
| Speed                      | 1750 rpm                        | Service Factor         | 1          |
| Efficiency                 | 85.2 %                          | Duty                   | Continuous |
| Insulation Class           | F                               | Frame                  | S56C       |
| Enclosure                  | Totally Enclosed Non Ventilated | Overload Protector     | No         |
| Ambient Temperature        | 40 °C                           | Drive End Bearing Size | 6203       |
| Opp Drive End Bearing Size | 6203                            | UL                     | Recognized |
| CSA                        | Y                               | CE                     | N          |

### Technical Specifications

|                 |               |                 |              |
|-----------------|---------------|-----------------|--------------|
| Rotation        | Reversible    | Mounting        | Rigid C base |
| Overall Length  | 14.63 in      | Frame Length    | 8.47 in      |
| Shaft Diameter  | 0.625 in      | Shaft Extension | 2.06 in      |
| Outline Drawing | 031900-108228 |                 |              |

This is an uncontrolled document once printed or downloaded and is subject to change without notice. Date Created: 10/15/2018

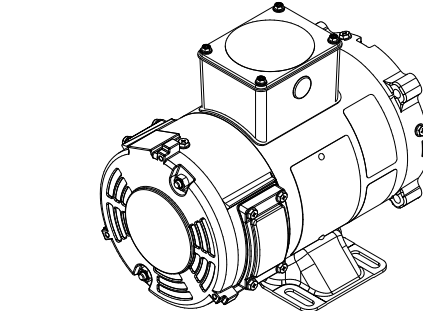
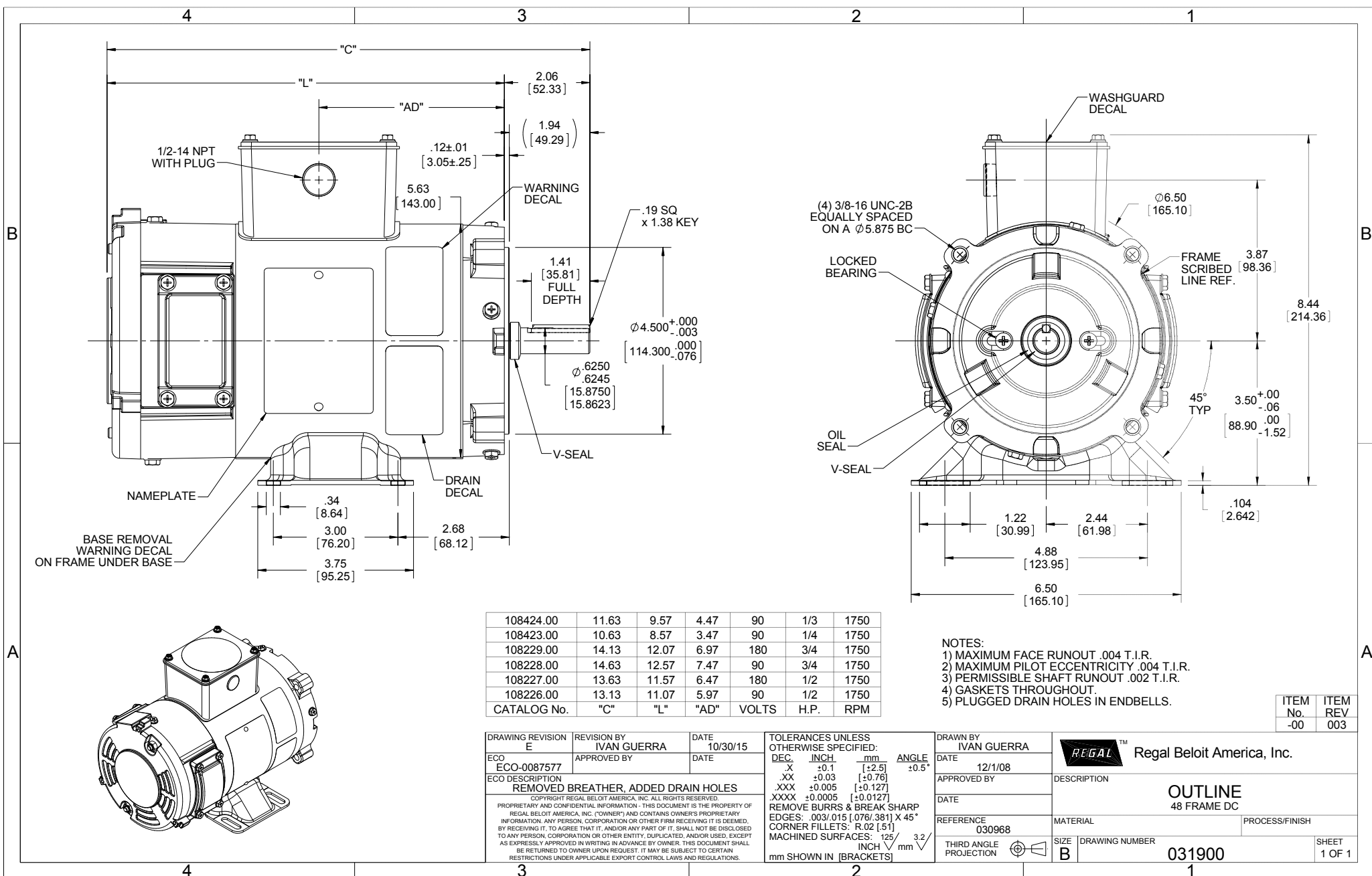

|             |       |       |      |       |      |      |
|-------------|-------|-------|------|-------|------|------|
| 108424.00   | 11.63 | 9.57  | 4.47 | 90    | 1/3  | 1750 |
| 108423.00   | 10.63 | 8.57  | 3.47 | 90    | 1/4  | 1750 |
| 108229.00   | 14.13 | 12.07 | 6.97 | 180   | 3/4  | 1750 |
| 108228.00   | 14.63 | 12.57 | 7.47 | 90    | 3/4  | 1750 |
| 108227.00   | 13.63 | 11.57 | 6.47 | 180   | 1/2  | 1750 |
| 108226.00   | 13.13 | 11.07 | 5.97 | 90    | 1/2  | 1750 |
| CATALOG No. | "C"   | "L"   | "AD" | VOLTS | H.P. | RPM  |

- NOTES:  
 1) MAXIMUM FACE RUNOUT .004 T.I.R.  
 2) MAXIMUM PILOT ECCENTRICITY .004 T.I.R.  
 3) PERMISSIBLE SHAFT RUNOUT .002 T.I.R.  
 4) GASKETS THROUGHOUT.  
 5) PLUGGED DRAIN HOLES IN ENDBELLS.

|          |          |
|----------|----------|
| ITEM No. | ITEM REV |
| -00      | 003      |

|                                                                                                                                                                                                                                                                                                                                                                                                                                                                                                                                                                                                                                                                                                                             |                            |                  |                                                                                                                                                                                                                                                                                                      |                                              |                                 |
|-----------------------------------------------------------------------------------------------------------------------------------------------------------------------------------------------------------------------------------------------------------------------------------------------------------------------------------------------------------------------------------------------------------------------------------------------------------------------------------------------------------------------------------------------------------------------------------------------------------------------------------------------------------------------------------------------------------------------------|----------------------------|------------------|------------------------------------------------------------------------------------------------------------------------------------------------------------------------------------------------------------------------------------------------------------------------------------------------------|----------------------------------------------|---------------------------------|
| DRAWING REVISION<br>E                                                                                                                                                                                                                                                                                                                                                                                                                                                                                                                                                                                                                                                                                                       | REVISION BY<br>IVAN GUERRA | DATE<br>10/30/15 | TOLERANCES UNLESS OTHERWISE SPECIFIED:<br>DEC. INCH mm ANGLE ±0.5°<br>-X ±0.1 [+2.5]<br>.XX ±0.03 [+0.76]<br>.XXX ±0.005 [+0.127]<br>.XXXX ±0.0005 [+0.0127]<br>REMOVE BURRS & BREAK SHARP<br>EDGES: .003/.015 [.076/.381] X 45°<br>CORNER FILLETS: R.02 [.51]<br>MACHINED SURFACES: 125/3.2 INCH/mm | DRAWN BY<br>IVAN GUERRA                      | Regal Beloit America, Inc.      |
| ECO<br>ECO-0087577                                                                                                                                                                                                                                                                                                                                                                                                                                                                                                                                                                                                                                                                                                          | APPROVED BY                | DATE             | DATE<br>12/1/08                                                                                                                                                                                                                                                                                      | DATE                                         |                                 |
| ECO DESCRIPTION<br>REMOVED BREATHER, ADDED DRAIN HOLES<br>COPYRIGHT REGAL BELOIT AMERICA, INC. ALL RIGHTS RESERVED.<br>PROPRIETARY AND CONFIDENTIAL INFORMATION - THIS DOCUMENT IS THE PROPERTY OF REGAL BELOIT AMERICA, INC. (OWNER) AND CONTAINS OWNER'S PROPRIETARY INFORMATION. ANY PERSON, CORPORATION OR OTHER FIRM RECEIVING IT IS DEEMED, BY RECEIVING IT, TO AGREE THAT IT, AND/OR ANY PART OF IT, SHALL NOT BE DISCLOSED TO ANY PERSON, CORPORATION OR OTHER ENTITY, DUPLICATED, AND/OR USED, EXCEPT AS EXPRESSLY APPROVED IN WRITING IN ADVANCE BY OWNER. THIS DOCUMENT SHALL BE RETURNED TO OWNER UPON REQUEST. IT MAY BE SUBJECT TO CERTAIN RESTRICTIONS UNDER APPLICABLE EXPORT CONTROL LAWS AND REGULATIONS. |                            |                  | REFERENCE<br>030968                                                                                                                                                                                                                                                                                  | DESCRIPTION<br><b>OUTLINE</b><br>48 FRAME DC | PROCESS/FINISH                  |
|                                                                                                                                                                                                                                                                                                                                                                                                                                                                                                                                                                                                                                                                                                                             |                            |                  | THIRD ANGLE PROJECTION                                                                                                                                                                                                                                                                               | MATERIAL                                     | DRAWING NUMBER<br><b>031900</b> |
|                                                                                                                                                                                                                                                                                                                                                                                                                                                                                                                                                                                                                                                                                                                             |                            |                  | SIZE<br>B                                                                                                                                                                                                                                                                                            |                                              | SHEET<br>1 OF 1                 |