

PRODUCT INFORMATION PACKET



Model No: C830V1
Catalog No: C830V1

1 HP General Purpose Motor, 1 phase, 1800 RPM, 115/208-230 V, 56HC Frame, TEFC
Single Phase TEFC Motors



Regal and Century are trademarks of Regal Beloit Corporation or one of its affiliated companies.
©2019 Regal Beloit Corporation, All Rights Reserved. MC017097E

The REGAL logo consists of the word 'REGAL' in a bold, white, sans-serif font, set against a dark grey, trapezoidal background.



Nameplate Specifications

Output HP	1 Hp	Output KW	0.75 kW
Frequency	60 Hz	Voltage	115/208-230 V
Current	14/6.8-7.0 A	Speed	1725 rpm
Service Factor	1.15	Phase	1
Duty	Continuous	Insulation Class	B
Frame	56HC	Enclosure	Totally Enclosed Fan Cooled
Thermal Protection	No	Ambient Temperature	40 °C
UL	Recognized	CSA	Y
CE	Y		

Technical Specifications

Electrical Type	Capacitor Start Induction Run	Starting Method	Across The Line
Poles	4	Rotation	Selective Counterclockwise
Mounting	Rigid Base	Drive End Bearing	Ball
Opp Drive End Bearing	Ball	Frame Material	Rolled Steel
Shaft Type	NEMA 56	Overall Length	13.16 in
Frame Length	7.65 in	Shaft Diameter	0.625 in
Shaft Extension	1.88 in		

This is an uncontrolled document once printed or downloaded and is subject to change without notice. Date Created:30/10/2019

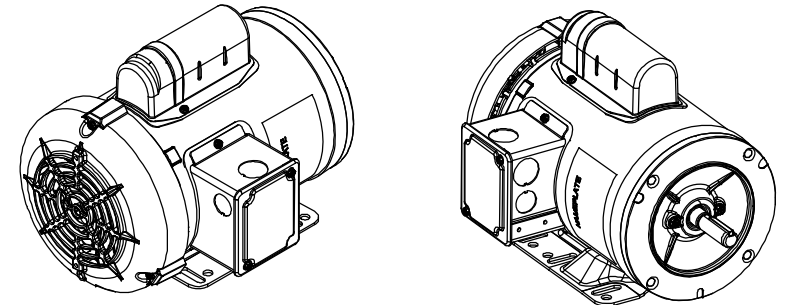
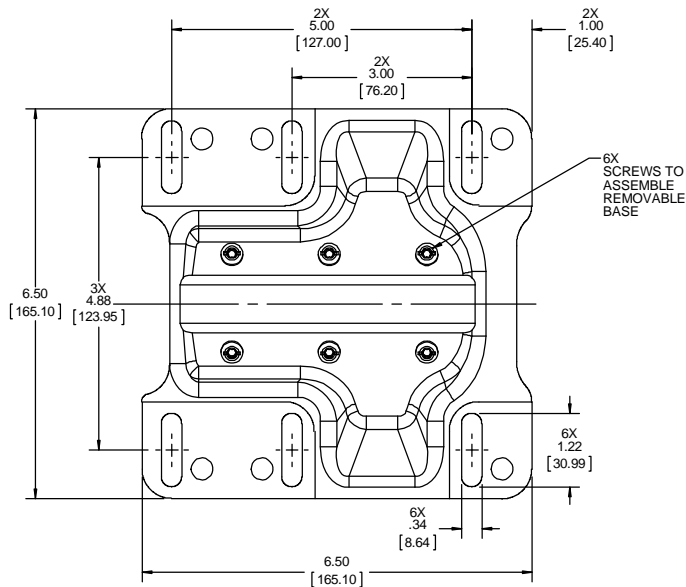
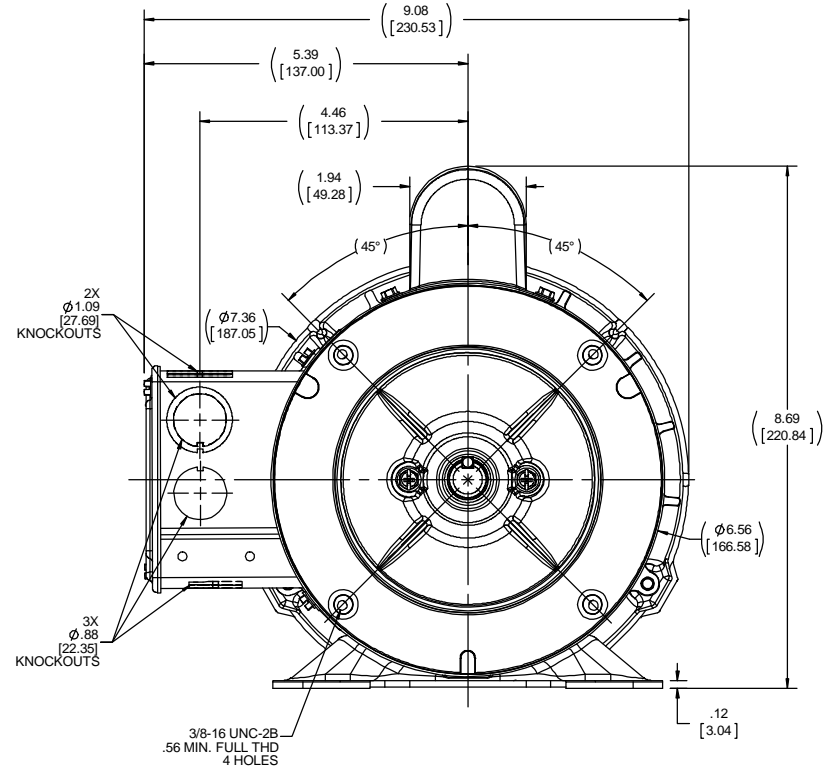
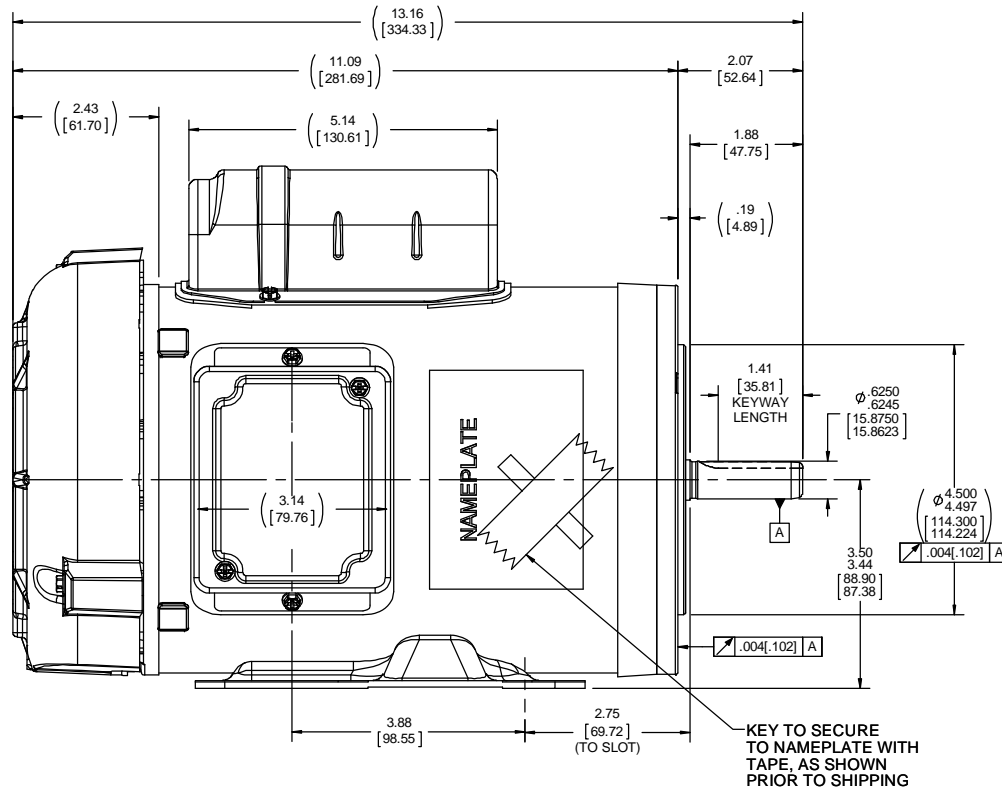

DRAWING REVISION A	REVISION BY DS	DATE 05/03/2018	TOLERANCES UNLESS OTHERWISE SPECIFIED: DEC. INCH mm ANGLE	DRAWN BY DS	 Regal Beloit America, Inc.
ECO ECO-0142904	APPROVED BY SAM	DATE 05/03/2018	.X ±0.1 [±2.5] .XX ±0.02 [±0.51] .XXX ±0.005 [±0.127] .XXXX ±0.0005 [±0.0127]	DATE 05/03/2018	
ECO DESCRIPTION NEW RELEASE			REMOVE BURRS & BREAK SHARP EDGES: .003/.015 [0.076/.381] X 45° CORNER FILLETS: R.02 [.51]	APPROVED BY SAM	DESCRIPTION OUTLINE
COPYRIGHT REGAL BELOIT AMERICA, INC. ALL RIGHTS RESERVED. PROPRIETARY AND CONFIDENTIAL INFORMATION. THIS DOCUMENT IS THE PROPERTY OF REGAL BELOIT AMERICA, INC. FORMERLY AND CONTAINS OWNERS PROPRIETARY INFORMATION. ANY PERSON, CORPORATION OR OTHER FIRM RECEIVING IT IS DEEMED BY RECEIVING IT, TO AGREE THAT IT, AND/OR ANY PART OF IT, SHALL NOT BE DISCLOSED TO ANY PERSON, CORPORATION OR OTHER ENTITY, DUPLICATED, AND/OR USED, EXCEPT AS EXPRESSLY APPROVED IN WRITING IN ADVANCE BY OWNER. THIS DOCUMENT SHALL BE RETURNED TO OWNER UPON REQUEST. IT MAY BE SUBJECT TO CERTAIN RESTRICTIONS UNDER APPLICABLE EXPORT CONTROL LAWS AND REGULATIONS.			MACHINED SURFACES: 125 / 3.2 INCH/ mm SHOWN IN (BRACKETS)	DATE 05/03/2018	MATERIAL 56H FR, TEFC, C-FACE, RIGID
			THIRD ANGLE PROJECTION	REFERENCE	PROCESS/FINISH
			SIZE C	DRAWING NUMBER OL56100459-001	SHEET 1 OF 1