

PRODUCT INFORMATION PACKET



Model No: C316ES
Catalog No: C316ES
.75 HP General Purpose Motor, 1 phase, 1800 RPM, 115/230 V, 56C Frame, ODP
Single Phase ODP Motors



Regal and Century are trademarks of Regal Beloit Corporation or one of its affiliated companies.
©2019 Regal Beloit Corporation, All Rights Reserved. MC017097E

The REGAL logo consists of the word 'REGAL' in a bold, white, sans-serif font, set against a dark grey rectangular background with a slight shadow effect.

REGAL



Nameplate Specifications

Output HP	.75 Hp	Output KW	0.56 kW
Frequency	60 Hz	Voltage	115/230 V
Current	6.6/3.3 A	Speed	1725 rpm
Service Factor	1.25	Phase	1
Duty	Continuous	Insulation Class	B
Frame	56C	Enclosure	Open Drip Proof
Thermal Protection	None	Ambient Temperature	40 °C
UL	Recognized	CSA	Y
CE	Y		

Technical Specifications

Electrical Type	Capacitor Start, Induction Run, Single Or Dual Voltage	Starting Method	Across The Line
Poles	4	Rotation	Clockwise/Counterclockwise
Mounting	Round	Drive End Bearing	Ball
Opp Drive End Bearing	Ball	Frame Material	Rolled Steel
Shaft Type	Keyed	Overall Length	11.44 in
Frame Length	7.25 in	Shaft Diameter	0.625 in
Shaft Extension	2.06 in		

This is an uncontrolled document once printed or downloaded and is subject to change without notice. Date Created:30/10/2019

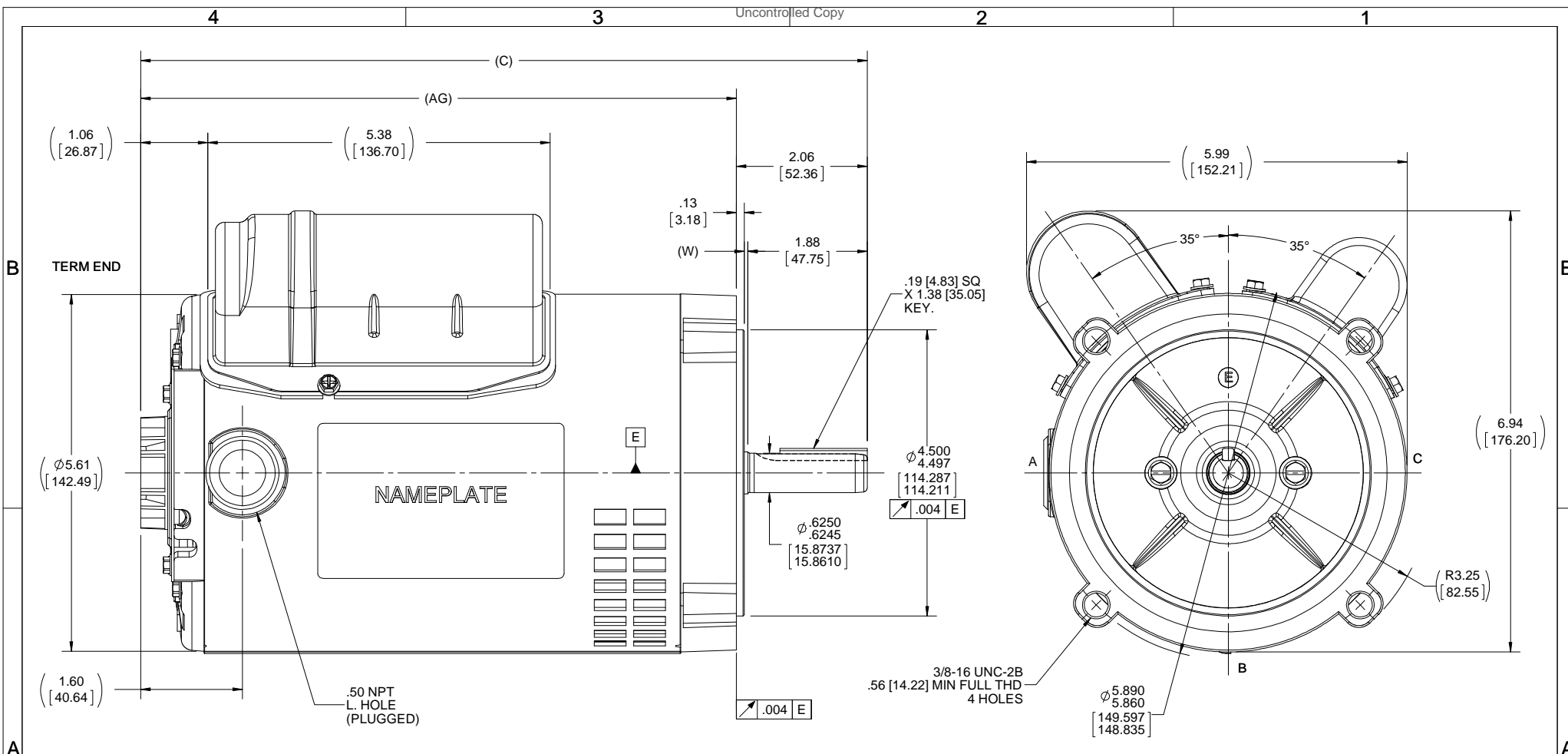

DASH	"C"	"AG"
625	10.18 [258.57]	8.12 [206.25]
650	10.43 [264.92]	8.37 [212.59]
675	10.68 [271.27]	8.62 [218.95]
700	10.93 [277.62]	8.87 [225.29]
725	11.18 [283.97]	9.12 [231.65]
750	11.43 [290.32]	9.37 [237.99]
775	11.68 [283.97]	9.62 [244.35]
800	11.93 [290.32]	9.87 [250.69]

NOTE:-
 1) NAMEPLATE LOCATION AT "A" READ FROM TERM.END.
 2) "W"=CLEARANCE ALLOWED FOR ALL VARIANCES IN MANUFACTURING & ASSEMBLY.

DRAWING REVISION D	REVISION BY A SUPPANAVAR	DATE 11/12/2018	TOLERANCES UNLESS OTHERWISE SPECIFIED: DEC. INCH mm ANGLE -X +0.1 [+2.5] ±7-30° .XX ±0.03 [+0.76] .XXX ±0.005 [+0.127] .XXXX ±0.0005 [+0.0127]	DRAWN BY JAH	Regal Beloit America, Inc.	
ECO ECO-0157672	APPROVED BY J DAS	DATE 12/03/2018	DATE 11/17/2014	DATE 11/17/2014		
ECO DESCRIPTION OUTLINE CONVERSION PROJECT <small>COPYRIGHT REGAL BELOIT AMERICA, INC. ALL RIGHTS RESERVED. PROPRIETARY AND CONFIDENTIAL INFORMATION - THIS DOCUMENT IS THE PROPERTY OF REGAL BELOIT AMERICA, INC. ("OWNER") AND CONTAINS OWNER'S PROPRIETARY INFORMATION. ANY PERSON, CORPORATION OR OTHER FIRM RECEIVING IT IS DEEMED, BY RECEIVING IT, TO AGREE THAT IT, AND/OR ANY PART OF IT, SHALL NOT BE DISCLOSED TO ANY PERSON, CORPORATION OR OTHER ENTITY, DUPLICATED, AND/OR USED, EXCEPT AS EXPRESSLY APPROVED IN WRITING IN ADVANCE BY OWNER. THIS DOCUMENT SHALL BE RETURNED TO OWNER UPON REQUEST. IT MAY BE SUBJECT TO CERTAIN RESTRICTIONS UNDER APPLICABLE EXPORT CONTROL LAWS AND REGULATIONS.</small>			REFERENCE SS404112	DESCRIPTION OUTLINE	PROCESS/FINISH	
MATERIAL			THIRD ANGLE PROJECTION	SIZE B	DRAWING NUMBER SS404112	SHEET 1 OF 1