

# PRODUCT INFORMATION PACKET



Model No: C311V1  
Catalog No: C311V1

0.5 HP General Purpose Farm Duty Motor, 1 phase, 1800 RPM, 115/230 V, 56 Frame, TEFC  
Single Phase Farm Duty Motors



Regal and Century are trademarks of Regal Beloit Corporation or one of its affiliated companies.  
©2019 Regal Beloit Corporation, All Rights Reserved. MC017097E

REGAL



**Nameplate Specifications**

Output HP	<b>0.5 Hp</b>	Output KW	<b>0.37 kW</b>
Frequency	<b>60 Hz</b>	Voltage	<b>115/230 V</b>
Current	<b>6.8/3.4 A</b>	Speed	<b>1725 rpm</b>
Service Factor	<b>1.25</b>	Phase	<b>1</b>
Duty	<b>Continuous</b>	Insulation Class	<b>B</b>
Frame	<b>56</b>	Enclosure	<b>Totally Enclosed Fan Cooled</b>
Thermal Protection	<b>Thermally Protected</b>	Ambient Temperature	<b>40 °C</b>
UL	<b>Recognized</b>	CSA	<b>Y</b>
CE	<b>Y</b>		

**Technical Specifications**

Electrical Type	<b>Capacitor Start Induction Run</b>	Starting Method	<b>Across The Line</b>
Poles	<b>4</b>	Rotation	<b>Selective Counterclockwise</b>
Mounting	<b>Rigid Base</b>	Drive End Bearing	<b>Ball</b>
Opp Drive End Bearing	<b>Ball</b>	Frame Material	<b>Rolled Steel</b>
Shaft Type	<b>Keyed</b>	Overall Length	<b>12.24 in</b>
Frame Length	<b>6.65 in</b>	Shaft Diameter	<b>0.625 in</b>
Shaft Extension	<b>1.88 in</b>		

This is an uncontrolled document once printed or downloaded and is subject to change without notice. Date Created:30/10/2019

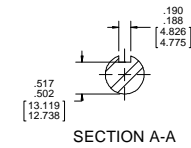
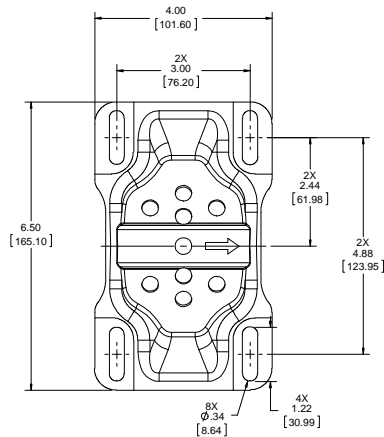
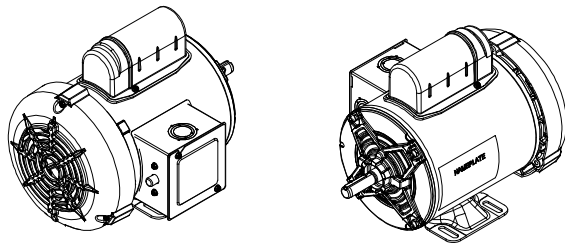
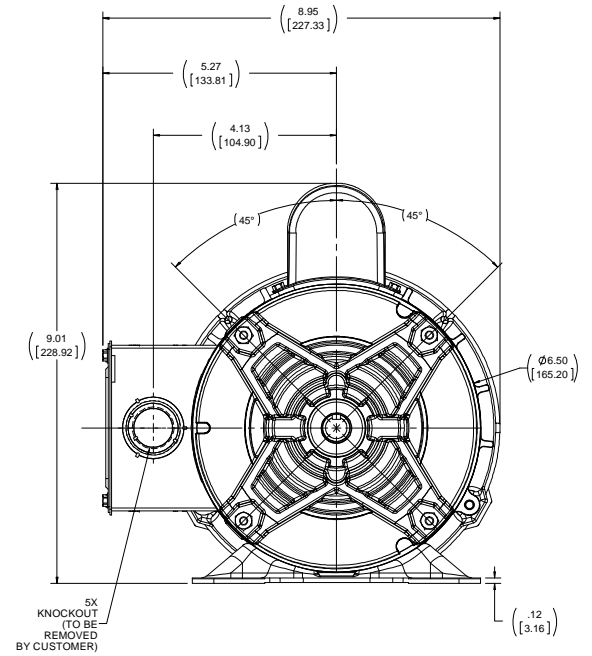
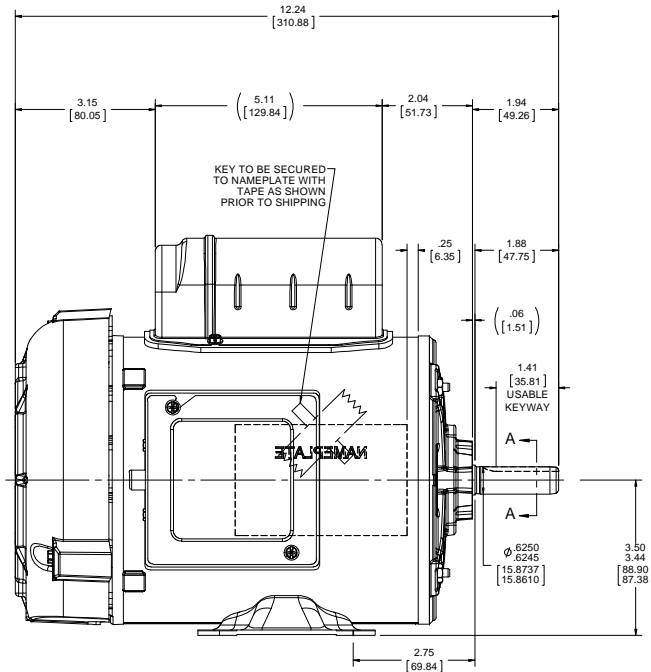
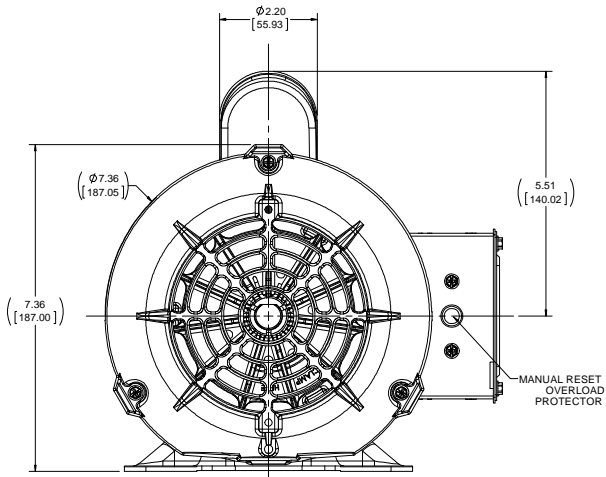

DRAWING REVISION A		REVISION BY MARGUELLES	DATE 01-03-2018	TOLERANCES UNLESS OTHERWISE SPECIFIED: FRACTIONS DECIMALS ANGLES X .01 .005 17 30" XX .005 .001 15 15" XXX .0005 (0.0127) XXXX .0005 (0.0127)		DRAWN BY MARGUELLES	Regal Beloit America, Inc.
ECO-0137046		APPROVED BY	DATE	FRACTIONS DECIMALS ANGLES X .01 .005 17 30" XX .005 .001 15 15" XXX .0005 (0.0127) XXXX .0005 (0.0127)		DATE	DESCRIPTION OUTLINE
NEW MODEL RELEASE		DATE		MATERIAL		56 FR,TEFC,NSDD	PROCESS/FINISH
REGAL BELLOIT AMERICA, INC. COMPANY AND CUSTOMER PROPERTY. THIS DRAWING IS THE PROPERTY OF REGAL BELLOIT AMERICA, INC. COMPANY AND CUSTOMER PROPERTY. IT IS TO BE USED ONLY FOR THE PURCHASE OF REGAL BELLOIT AMERICA, INC. COMPANY PRODUCTS. IT IS NOT TO BE REPRODUCED, COPIED, OR TRANSMITTED IN ANY FORM OR BY ANY MEANS, ELECTRONIC OR MECHANICAL, INCLUDING PHOTOCOPYING, RECORDING, OR BY ANY INFORMATION STORAGE AND RETRIEVAL SYSTEM. WITHOUT PERMISSION IN WRITING FROM REGAL BELLOIT AMERICA, INC. COMPANY. ALL RIGHTS ARE RESERVED. REGAL BELLOIT AMERICA, INC. COMPANY IS NOT RESPONSIBLE FOR ANY DAMAGE TO PROPERTY OR PERSONS ARISING FROM THE USE OF THIS DRAWING.		MATERIAL		REFERENCE		THIRD ANGLE PROJECTION	DRAWING NUMBER OL56100456-001
MATERIAL		REFERENCE		THIRD ANGLE PROJECTION		SIZE D	SHEET 1 OF 1