

# PRODUCT INFORMATION PACKET



Model No: C151L  
Catalog No: C151L  
1/3 HP General Purpose Motor, 1 phase, 1800 RPM, 115/230 V, 48 Frame, TENV  
Single Phase TENV Motors



Regal and Century are trademarks of Regal Beloit Corporation or one of its affiliated companies.

©2019 Regal Beloit Corporation, All Rights Reserved. MC017097E





**Nameplate Specifications**

Output HP	1/3 Hp	Output KW	0.25 kW
Frequency	60 Hz	Voltage	115/230 V
Current	4.6/2.3 A	Speed	1725 rpm
Service Factor	1	Phase	1
Duty	Continuous	Insulation Class	B
Frame	48	Enclosure	Totally Enclosed Non Ventilated
Thermal Protection	Automatic	Ambient Temperature	40 °C
UL	Recognized	CSA	Y
CE	N		

**Technical Specifications**

Electrical Type	Capacitor Start Induction Run	Starting Method	Across The Line
Poles	4	Rotation	Reversible
Mounting	Rigid Base	Drive End Bearing	Ball
Opp Drive End Bearing	Ball	Frame Material	Rolled Steel
Shaft Type	Flat	Overall Length	9.90 in
Frame Length	5.31 in	Shaft Diameter	0.500 in
Shaft Extension	1.62 in		

This is an uncontrolled document once printed or downloaded and is subject to change without notice. Date Created:30/10/2019

# Uncontrolled Copy

REV	ECO	REV BY	DATE	APPD	DATE
C	0025577	H.ZHANG	04-24-2012	B.SHEN	04-24-2012

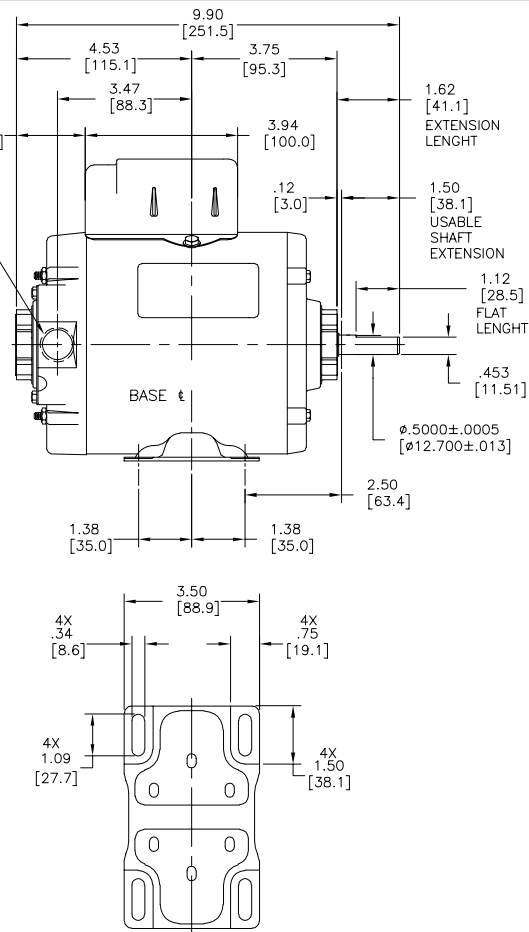
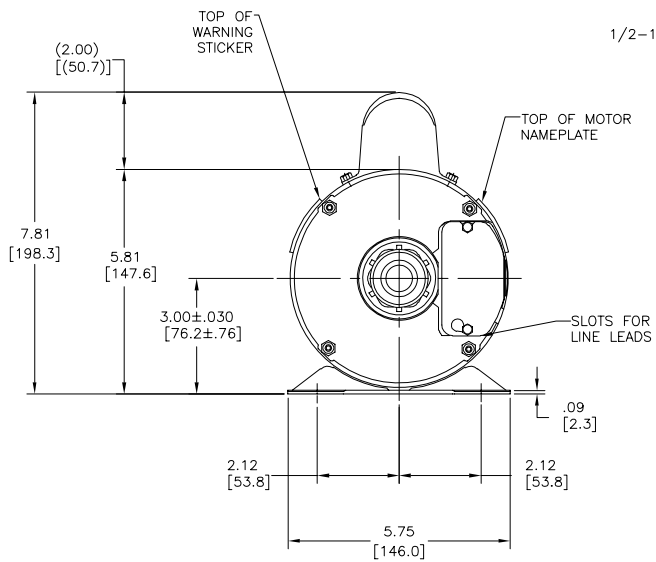

BOTTOM VIEW OF BASE

GEOMETRIC CHARACTERISTICS & SYMBOLS	
∟	FLATNESS
—	STRAIGHTNESS
∠	ANGULARITY
⊥	PERPENDICULARITY (SQUARENESS)
∥	PARALLELISM
○	ROUNDNESS (CIRCULARITY)
⊘	CYLINDRICITY
⊖	PROFILE OF ANY SURFACE
∩	ROUNDNESS (CIRCULARITY)
↑	RUNOUT
★	TRUE POSITION
◎	CONCENTRICITY
≡	SYMMETRY

UNLESS OTHERWISE SPECIFIED DIM. TOLERANCES ARE AS FOLLOWS:	
INCH	X XX XXX XXXX
mm	±.1 ±.02 ±.005 ±.0005
mm	±0.5 ±0.13 ±0.013
ANG.	±.50 DEG
REMOVE BURRS & BREAK SHARP EDGES:	
INCH	.003-015
mm	0.1-0.4
CORNER FILLETS TO:	
INCH	.020
mm	0.5
MACHINE SURFACES:	
INCH	125
mm	3.2
METRIC DIMS. SHOWN IN [BRACKETS]	

DR BY:	E. OCHOA	09/13/2008
APPD:	TONY COLOMA	09/13/2008
EDS DATE	11-11-2011	
FORMAT	REV	G
THIRD ANGLE PROJECTION		
CONFIDENTIAL: THIS DRAWING AND ITS INFORMATION ARE THE EXCLUSIVE AND CONFIDENTIAL PROPERTY OF REGAL-BELOIT CORPORATION AND ARE NOT TO BE DISCLOSED, DUPLICATED, DISTRIBUTED OR OTHERWISE USED WITHOUT THE WRITTEN CONSENT OF REGAL-BELOIT CORPORATION. -ALL RIGHTS RESERVED.		

REGAL-BELOIT CORPORATION	
DESCRIPTION	OUTLINE
SIZE	C
DWG NO	C151L
SCALE	NONE
SHEET	1

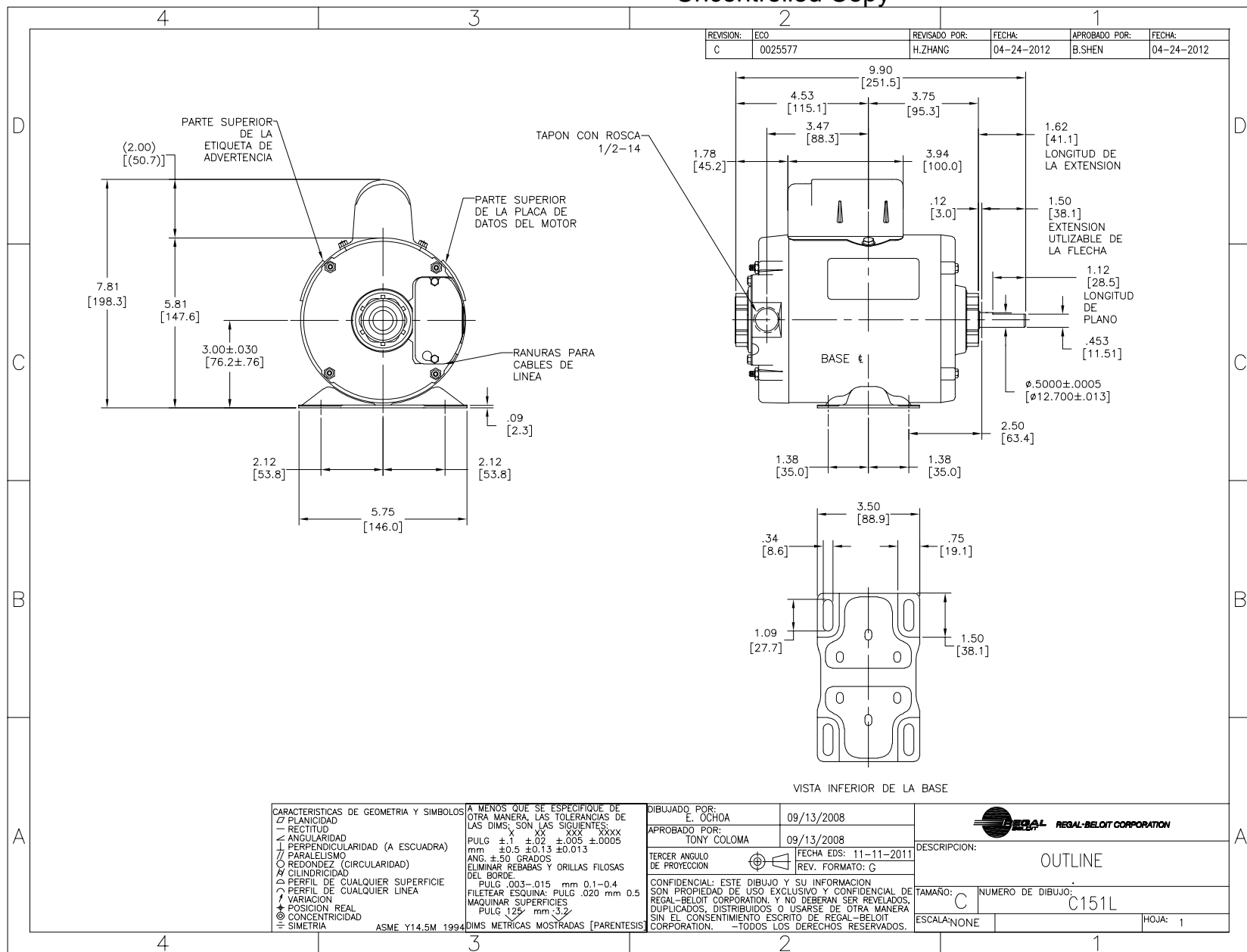

REVISION:	ECO	REVISADO POR:	H.ZHANG	FECHA:	04-24-2012	APROBADO POR:	B.SHEN	FECHA:	04-24-2012
	C								

CARACTERISTICAS DE GEOMETRIA Y SIMBOLOS ▽ PLANICIDAD — RECTITUD ∠ ANGULARIDAD ⊥ PERPENDICULARIDAD (A ESQUADRA) // PARALELISMO ○ REDONDEZ (CIRCULARIDAD) ∅ CILINDRICIDAD ≡ PERFIL DE CUALQUIER SUPERFICIE ~ PERFIL DE CUALQUIER LINEA ↑ VARIACION ★ POSICION REAL ⊙ CONCENTRICIDAD = SIMETRIA	A MENOS QUE SE ESPECIFIQUE DE OTRA MANERA, LAS TOLERANCIAS DE LAS DIMS. SON LAS SIGUIENTES: PULG. ±.1 ±.02 ±.005 ±.0005 mm ±0.5 ±0.13 ±0.013 ANG. ±50 GRADOS ELIMINAR REBASAS Y ORILLAS FILOSAS DEL BORDE. PULG. .003-.015 mm 0.1-0.4 FILETEAR ESQUINA: PULG. .020 mm 0.5 MAQUINAR SUPERFICIES PULG. 125 mm -3.2
---	--

DIMS. METRICAS MOSTRADAS [PARENTESIS] ASME Y14.5M 1994
---

DIBUJADO POR:	E. OCHOA	09/13/2008
APROBADO POR:	TONY COLOMA	09/13/2008
TERCER ANGULO DE PROYECCION		FECHA EDS: 11-11-2011 REV. FORMATO: G
CONFIDENCIAL: ESTE DIBUJO Y SU INFORMACION SON PROPIEDAD DE USO EXCLUSIVO Y CONFIDENCIAL DE REGAL-BELOIT CORPORATION, Y NO DEBERAN SER REVELADOS, DUPLICADOS, DISTRIBUIDOS O USARSE DE OTRA MANERA SIN EL CONSENTIMIENTO ESCRITO DE REGAL-BELOIT CORPORATION. -TODOS LOS DERECHOS RESERVADOS.		

REGAL-BELOIT CORPORATION	
DESCRIPCION:	OUTLINE
TAMAÑO:	C
NUMERO DE DIBUJO:	C151L
ESCALA:	NONE
HOJA:	1

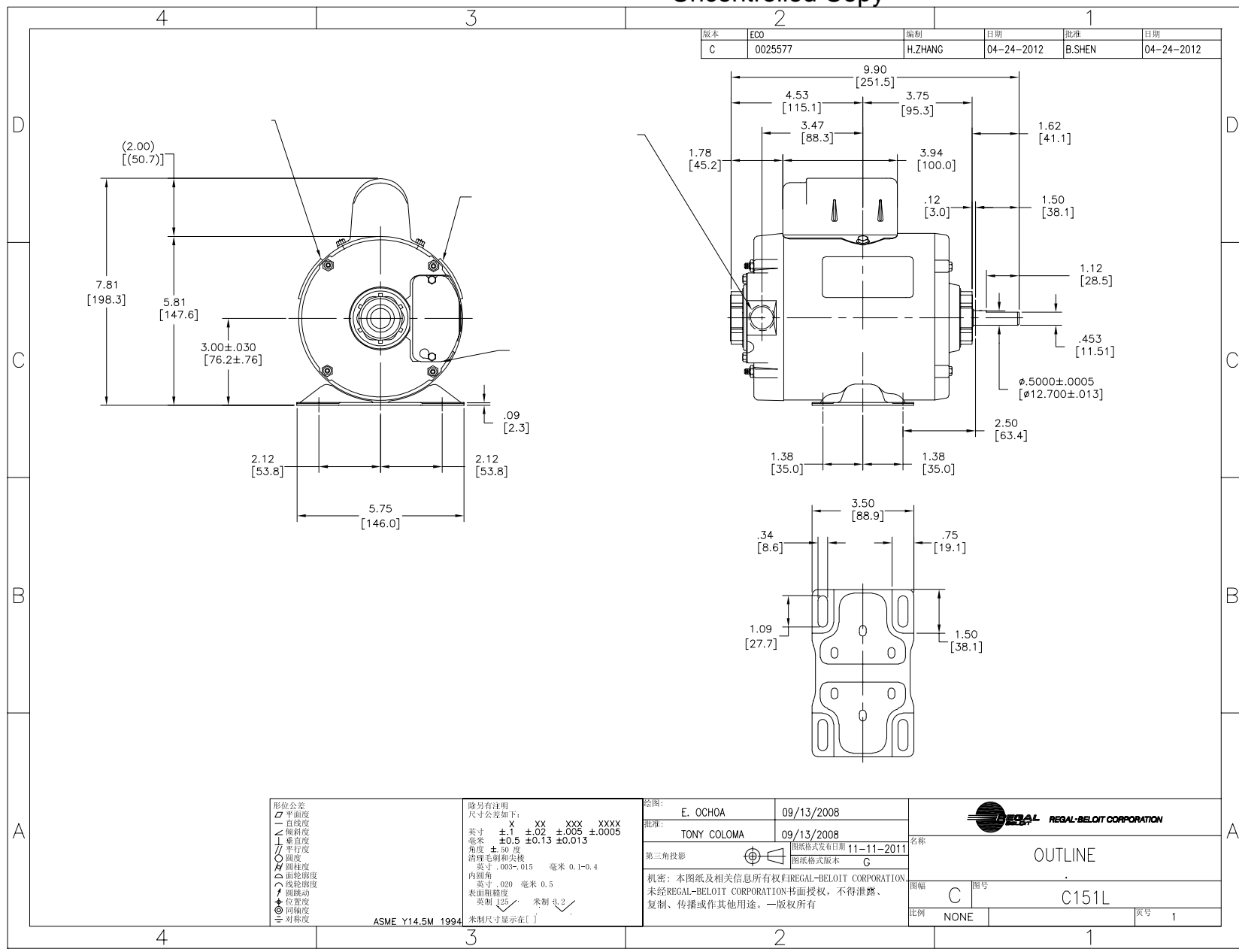

版本	ECO	编制	日期	批准	日期
C	0025577	H.ZHANG	04-24-2012	B.SHEN	04-24-2012

形位公差	除另有注明
□ 平面度	尺寸公差如下:
— 直线度	英寸 X XX XXX XXXX
∠ 垂直度	毫米 ±1 ±.02 ±.005 ±.0005
∥ 平行度	毫米 ±0.5 ±0.13 ±0.013
⊥ 垂直度	角度 ±.50 度
○ 圆度	清理毛刺和尖棱
⊙ 圆跳动	英寸 .003-.015 毫米 0.1-0.4
⊙ 面轮廓度	内圆角
⊙ 线轮廓度	英寸 .020 毫米 0.5
⊙ 圆跳动	表面粗糙度
⊙ 位置度	英制 125 米制 3.2
⊙ 对称度	米制尺寸显示在 [ ]

ASME Y14.5M 1994
------------------

绘图:	E. OCHOA	09/13/2008
批准:	TONY COLOMA	09/13/2008
第三角投影		
图底格式发布日期	11-11-2011	
图底格式版本	G	
机密: 本图纸及相关信息所有权归REGAL-DELOIT CORPORATION. 未经REGAL-DELOIT CORPORATION书面授权, 不得泄露、复制、传播或作其他用途。—版权所有		

名称	OUTLINE
图幅	C
图号	C151L
比例	NONE
页号	1