

PRODUCT INFORMATION PACKET



Model No: B664

Catalog No: B664

3/4 HP General Purpose Motor, 1 phase, 3600 RPM, 208-230/115 V, 56 Frame, TEFC
Single Phase TENV Motors



Regal and Century are trademarks of Regal Beloit Corporation or one of its affiliated companies.

©2019 Regal Beloit Corporation, All Rights Reserved. MC017097E

The REGAL logo consists of the word 'REGAL' in a bold, white, sans-serif font, set against a dark grey, trapezoidal background with a slight shadow effect.

REGAL



Nameplate Specifications

Output HP	3/4 Hp	Output KW	0.56 kW
Frequency	60 Hz	Voltage	208-230/115 V
Current	5.0-4.6/9.2 A	Speed	3450 rpm
Service Factor	1.15	Phase	1
Duty	Continuous	Insulation Class	B
Frame	J56	Enclosure	Totally Enclosed Fan Cooled
Thermal Protection	None	Ambient Temperature	40 °C
UL	Recognized	CSA	Y
CE	N		

Technical Specifications

Electrical Type	Capacitor Start, Induction Run, Single Or Dual Voltage	Starting Method	Across The Line
Poles	2	Rotation	Reversible Counterclockwise
Mounting	Rigid Base	Drive End Bearing	Ball
Opp Drive End Bearing	Ball	Frame Material	Rolled Steel
Shaft Type	Keyed	Overall Length	12.24 in
Frame Length	5.13 in	Shaft Diameter	0.625 in
Shaft Extension	1.94 in		

This is an uncontrolled document once printed or downloaded and is subject to change without notice. Date Created:04/11/2019

Uncontrolled Copy

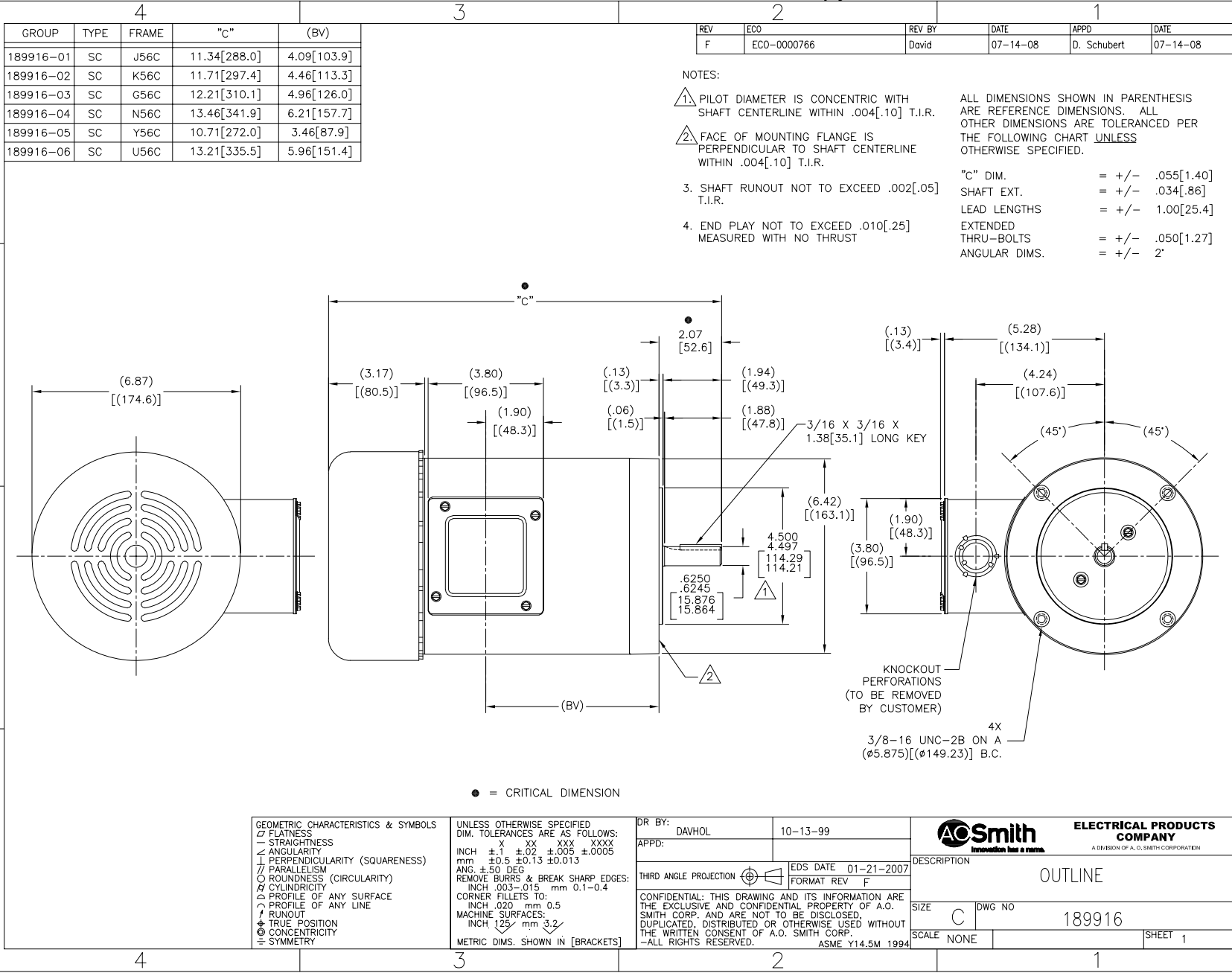

GEOMETRIC CHARACTERISTICS & SYMBOLS

- ▭ FLATNESS
- STRAIGHTNESS
- ∠ ANGULARITY
- ⊥ PERPENDICULARITY (SQUARENESS)
- ∥ PARALLELISM
- ROUNDNESS (CIRCULARITY)
- ⊘ CYLINDRICITY
- ⌒ PROFILE OF ANY SURFACE
- ⌒ PROFILE OF ANY LINE
- ↗ RUNOUT
- ⊕ TRUE POSITION
- ⊙ CONCENTRICITY
- ≡ SYMMETRY

UNLESS OTHERWISE SPECIFIED DIM. TOLERANCES ARE AS FOLLOWS:

INCH	±.1	±.02	±.005	±.0005
mm	±0.5	±0.13	±0.013	

ANG. ±.50 DEG
 REMOVE BURRS & BREAK SHARP EDGES:
 INCH .003-.015 mm 0.1-.04
 CORNER FILLETS TO:
 INCH .020 mm 0.5
 MACHINE SURFACES:
 INCH 125 mm 3.2
 METRIC DIMS. SHOWN IN [BRACKETS]

DR BY: DAVHOL	10-13-99
APPD:	
THIRD ANGLE PROJECTION	EDS DATE 01-21-2007 FORMAT REV F
CONFIDENTIAL: THIS DRAWING AND ITS INFORMATION ARE THE EXCLUSIVE AND CONFIDENTIAL PROPERTY OF A.O. SMITH CORP. AND ARE NOT TO BE DISCLOSED, DUPLICATED, DISTRIBUTED OR OTHERWISE USED WITHOUT THE WRITTEN CONSENT OF A.O. SMITH CORP. -ALL RIGHTS RESERVED.	
ASME Y14.5M 1994	

ACSmith <small>Innovation has a name.</small>		ELECTRICAL PRODUCTS COMPANY <small>A DIVISION OF A. O. SMITH CORPORATION</small>	
DESCRIPTION OUTLINE			
SIZE C	DWG NO 189916		
SCALE NONE		SHEET 1	

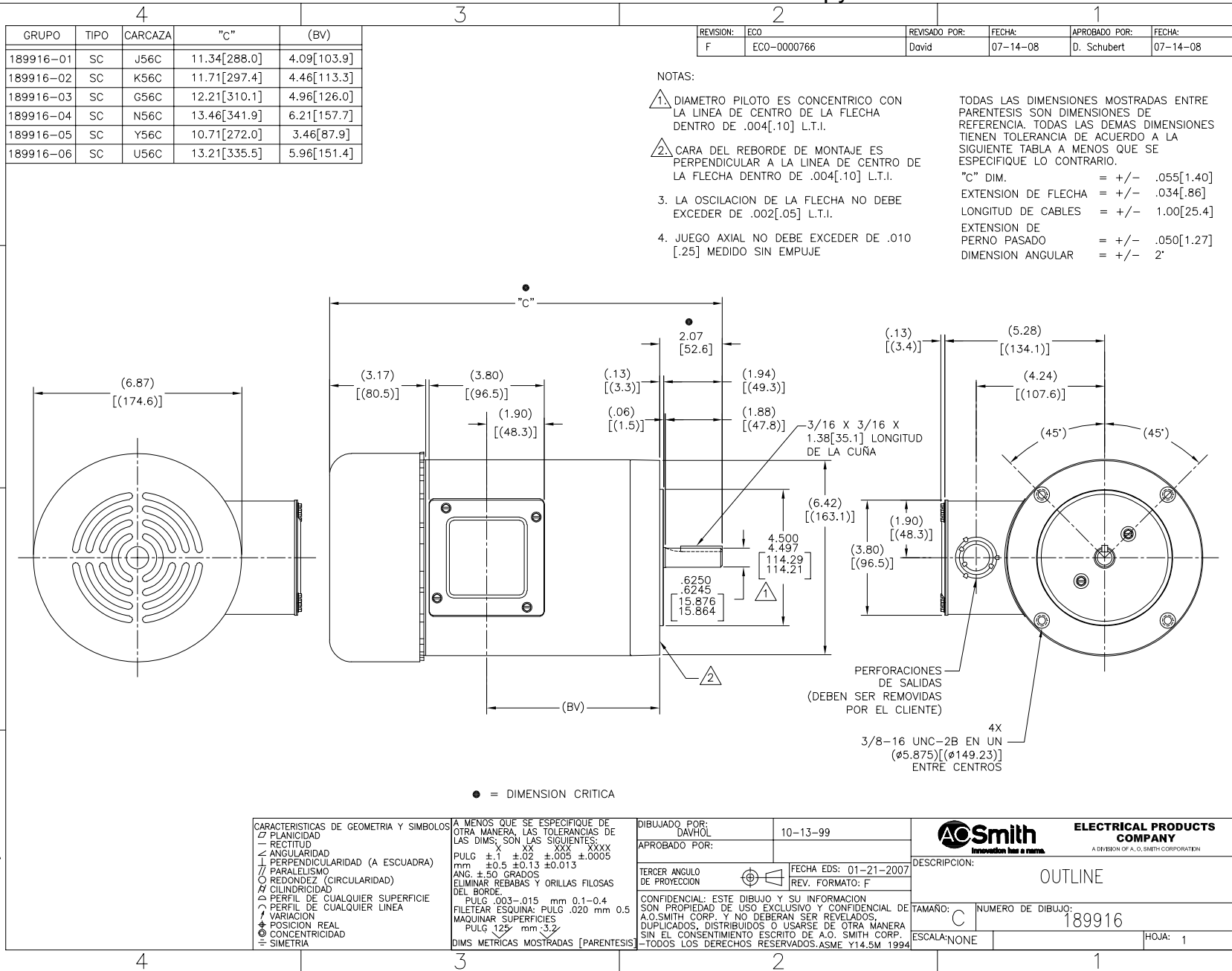

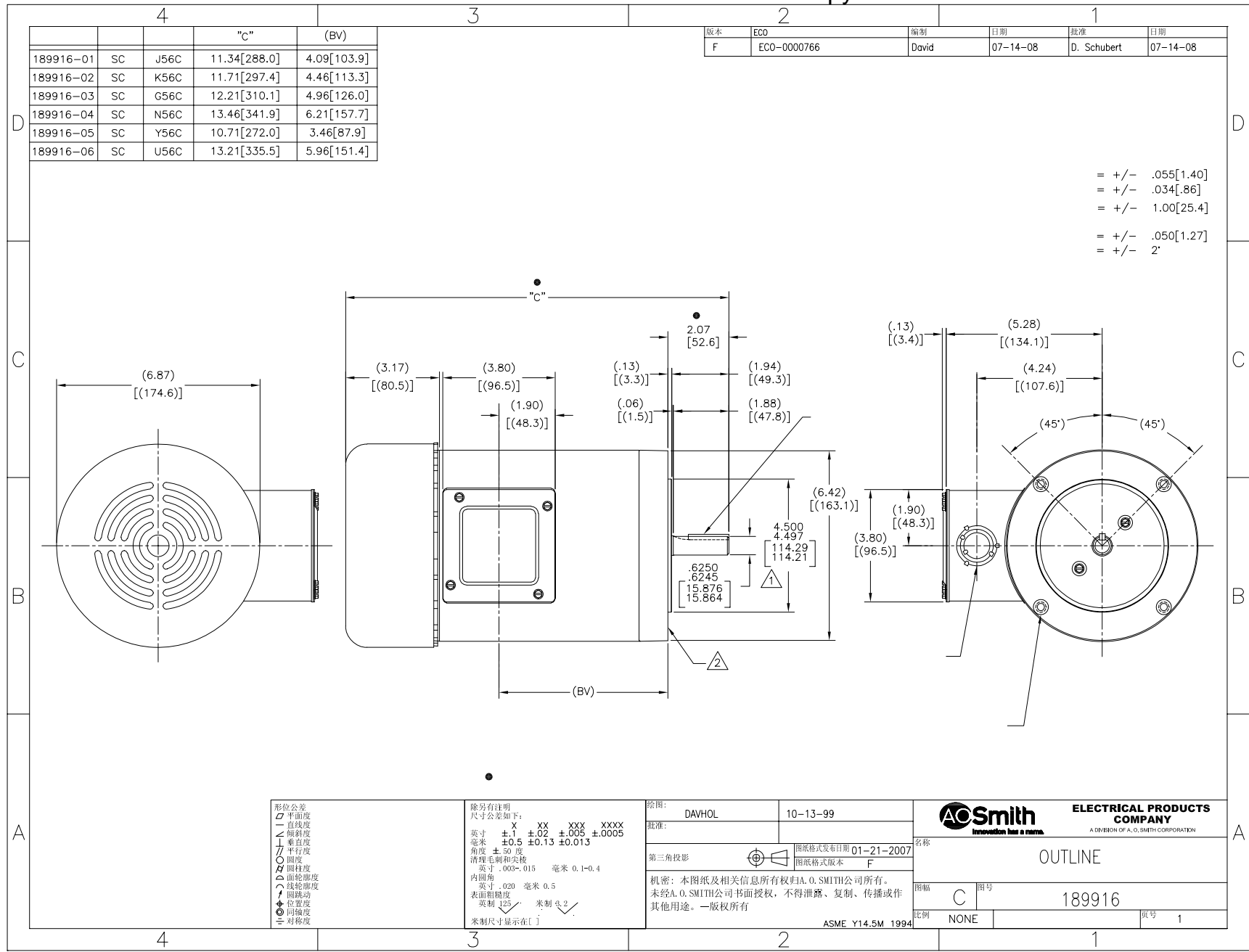

形位公差 □ 平面度 ⊥ 垂直度 ∥ 平行度 ○ 圆度 ⊙ 圆跳动 ⊕ 位置度 ⊖ 同轴度 ≡ 对称度	除另有注明 尺寸公差如下: 英寸 X XX XXX XXXX 毫米 ±.1 ±.02 ±.005 ±.0005 英寸 ±0.5 ±0.13 ±0.013 角度 ±.50 度 清理毛刺和尖棱 英寸 .003-.015 毫米 0.1-0.4 内圆角 英寸 .020 毫米 0.5 表面粗糙度 英制 125 米制 3.2 米制尺寸显示在 []	绘图: DAVHOL 10-13-99 批准: 第三角投影 图框格式发布日期 01-21-2007 图框格式版本 F 机密: 本图纸及相关信息所有权归A. O. SMITH公司所有。 未经A. O. SMITH公司书面授权, 不得泄露、复制、传播或作 其他用途。—版权所有 ASME Y14.5M 1994	ACSmith Innovation has a name. ELECTRICAL PRODUCTS COMPANY A DIVISION OF A. O. SMITH CORPORATION 名称 OUTLINE 图幅 C 图号 189916 比例 NONE 页号 1
---	---	--	--

REV	ECO	REV BY	DATE	APPD	DATE
Y	ECO-0022098	J. COX	04-24-2012	C. McREYNOLDS	04-24-2012

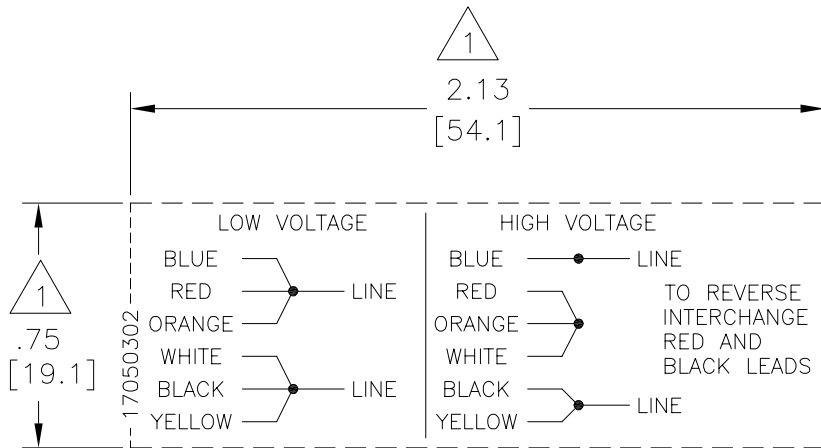

NOTES:

1. DOTTED BOX REPRESENTS TOTAL PRINTED AREA ALLOWED FOR CONNECTION DIAGRAM TO FIT IN. THIS AREA DOES NOT INCLUDE THE BORDER AROUND THE CONNECTION DIAGRAM. SEE NAMEPLATE DRAWING 170500 OR 170501 FOR LOCATION.
2. DETAILS ARE NOT TO BE COPIED FROM DRAWING, BUT ARE TO BE REPRODUCED FROM ORIGINAL ARTWORK FURNISHED.
3. CHARACTERS ARE TO BE A MINIMUM OF .03[.8] TO .06[1.5] MAXIMUM IN HEIGHT.

GEOMETRIC CHARACTERISTICS & SYMBOLS

- ▭ FLATNESS
- STRAIGHTNESS
- ∠ ANGULARITY
- ⊥ PERPENDICULARITY (SQUARENESS)
- ∥ PARALLELISM
- ROUNDNESS (CIRCULARITY)
- ⊘ CYLINDRICITY
- △ PROFILE OF ANY SURFACE
- ⌒ PROFILE OF ANY LINE
- ↶ RUNOUT
- ⊕ TRUE POSITION
- ⊗ CONCENTRICITY
- ⊖ SYMMETRY

ASME Y14.5M 1994

UNLESS OTHERWISE SPECIFIED
DIM. TOLERANCES ARE AS FOLLOWS:

INCH	±.1	±.02	±.005	±.0005
mm	±0.5	±0.13	±0.013	

ANG. ±.50 DEG
REMOVE BURRS & BREAK SHARP EDGES:
INCH .003-.015 mm 0.1-0.4

CORNER FILLETS TO:
INCH .020 mm 0.5

MACHINE SURFACES:
INCH 125 mm 3.2

METRIC DIMS. SHOWN IN [BRACKETS]

DR BY:	MLC	03-04-1985
APPD:	MLC	03-13-1985
THIRD ANGLE PROJECTION		EDS DATE 11-11-2011 FORMAT REV G
CONFIDENTIAL: THIS DRAWING AND ITS INFORMATION ARE THE EXCLUSIVE AND CONFIDENTIAL PROPERTY OF REGAL-BELOIT CORPORATION AND ARE NOT TO BE DISCLOSED, DUPLICATED, DISTRIBUTED OR OTHERWISE USED WITHOUT THE WRITTEN CONSENT OF REGAL-BELOIT CORPORATION. -ALL RIGHTS RESERVED.		

DESCRIPTION CONN DIAGRAM-NAMEPLATE	
SIZE A	DWG NO 17050302
SCALE NONE	SHEET 1

REVISION:	ECO	REVISADO POR:	J. COX	FECHA:	04-24-2012	APROBADO POR:	C. McREYNOLDS	FECHA:	04-24-2012
Y	ECO-0022098								

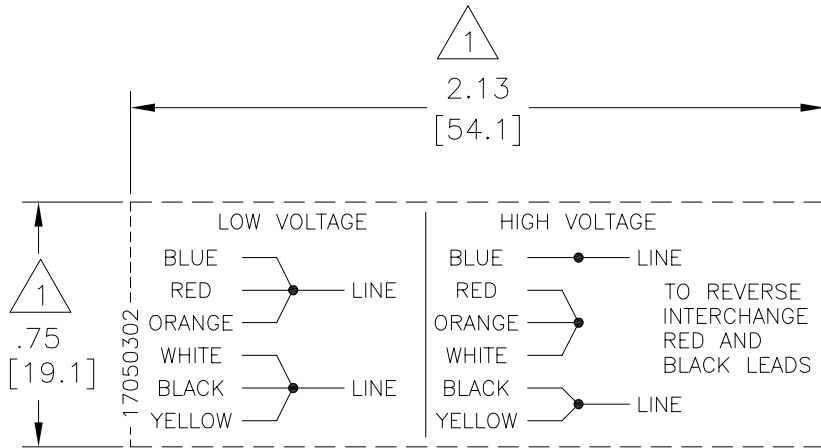

NOTAS:

- LA CAJA PUNTEADA REPRESENTA EL AREA TOTAL IMPRESA PERMITIDA PARA EL DIAGRAMA DE CONEXION PARA QUE ENCAJE EN ESTA AREA NO INCLUYE EL BORDE AL REDEDOR DEL DIAGRAMA DE CONEXION. VER DIBUJO DE PLACA DE DATOS 170500 O 170501 PARA UBICACION.
- LOS DETALLES NO DEBEN SER COPIADOS DEL DIBUJO, PERO VA A SER REPRODUCIDA DEL TRABAJO ORIGINAL SUMINISTRADO.
- LOS CARACTERES SON DE UN MINIMO DE .03[.8] A .06[1.5] EN ALTURA MAXIMA.

CARACTERISTICAS DE GEOMETRIA Y SIMBOLOS	/ PLANICIDAD — RECTITUD < ANGULARIDAD ⊥ PERPENDICULARIDAD (A ESCUADRA) // PARALELISMO ○ REDONDEZ (CIRCULARIDAD) ∅ CILINDRICIDAD △ PERFIL DE CUALQUIER SUPERFICIE ∩ PERFIL DE CUALQUIER LINEA ↑ VARIACION ⊕ POSICION REAL ⊙ CONCENTRICIDAD = SIMETRIA
---	--

A MENOS QUE SE ESPECIFIQUE DE OTRA MANERA, LAS TOLERANCIAS DE LAS DIMS, SON LAS SIGUIENTES: PULG ±.1 ±.02 ±.005 ±.0005 mm ±0.5 ±0.13 ±0.013 ANG. ±50 GRADOS ELIMINAR REBABAS Y ORILLAS FILOSAS DEL BORDE. PULG .003-.015 mm 0.1-0.4 FILETEAR ESQUINA: PULG .020 mm 0.5 MAQUINAR SUPERFICIES PULG 125 mm 3.2 DIMS METRICAS MOSTRADAS [PARENTESIS]

DIBUJADO POR:	MLC	03-04-1985
APROBADO POR:	MLC	03-13-1985
TERCER ANGULO DE PROYECCION		FECHA EDS: 11-11-2011 REV. FORMATO: G
CONFIDENCIAL: ESTE DIBUJO Y SU INFORMACION SON PROPIEDAD DE USO EXCLUSIVO Y CONFIDENCIAL DE REGAL-BELOIT CORPORATION Y NO DEBERAN SER REVELADOS, DUPLICADOS, DISTRIBUIDOS O USARSE DE OTRA MANERA SIN EL CONSENTIMIENTO ESCRITO DE REGAL-BELOIT CORPORATION.-TODOS LOS DERECHOS RESERVADOS.		

DESCRIPCION:	
CONN DIAGRAM-NAMEPLATE	
TAMAÑO: A	NUMERO DE DIBUJO: 17050302
ESCALA: NONE	HOJA: 1

版本	ECO	编制	日期	批准	日期
Y	ECO-0022098	J. COX	04-24-2012	C. McREYNOLDS	04-24-2012

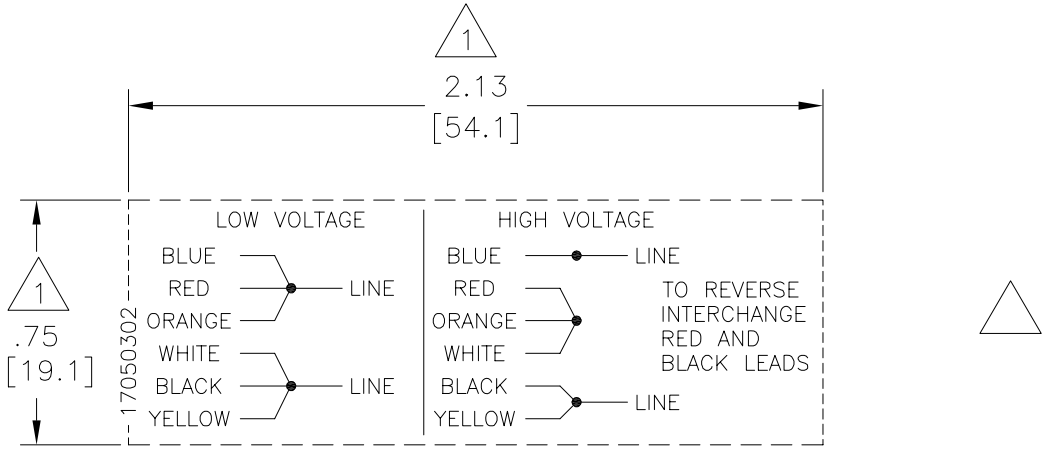

- 形位公差
- 平面度
- 直线度
- ∠ 倾斜度
- ⊥ 垂直度
- ∥ 平行度
- 圆度
- ⊘ 圆柱度
- 面轮廓度
- 线轮廓度
- 圆跳动
- 位置度
- 同轴度
- 对称度

除另有注明
尺寸公差如下:
 英寸 X XX XXX XXXX
 ±.1 ±.02 ±.005 ±.0005
 毫米 ±0.5 ±0.13 ±0.013
 角度 ±.50 度
 清理毛刺和尖棱
 英寸 .003-.015 毫米 0.1-0.4
 内圆角
 英寸 .020 毫米 0.5
 表面粗糙度
 英制 125 米制 3.2
 米制尺寸显示在 []

绘图:	MLC	03-04-1985
批准:	MLC	03-13-1985
第三角投影		图纸格式发布日期 11-11-2011 图纸格式版本 G
机密:本图纸及相关信息所有权归REGAL-BELOIT CORPORATION。未经REGAL-BELOIT CORPORATION书面授权,不得泄露、复制、传播或作其他用途。--版权所有		



名称		CONN DIAGRAM-NAMEPLATE	
图幅	A	图号	17050302
比例	NONE	页号	1

ASME Y14.5M 1994