

TYPE	OUTPUT		POLE	TIME RATING	VOLTAGE V	Hz	SYN.SPEED R.P.M
	HP.	kW.					
AMRC-YC	150	111	4	CONT	460	60	1800

ENCLOSED VENTILATED VERTICAL HOLLOW SHAFT TYPE, SQUIRREL CAGE ROTOR
NEMA WEATHER PROTECTED TYPE I

NOTE:

1. DIMENSIONS IN INCHES.
2. FRAME NO.444TP.
3. F CLASS INSULATION, S.F. 1.15.
4. FOR DIRECT FLEXIBLE COUPLING.
5. BEARING SIZE:
UPPER BEARING: 7324B [UNINSULATED]
LOWER BEARING: 6316C3 [UNINSULATED]
6. LUBRICATION:
UPPER BEARING USE OIL.
OIL VISCOSITY: ISO VG68[300 SSU/100°F]
OIL QUANTITY: 3.5GAL.
LOWER BEARING USE ESSD POLYREX GREASE.
7. THRUST CAPACITY:
MAX. ALLOWABLE CONT. DOWNTHRUST: 10,000 LBS.
MAX. ALLOWABLE MOMENTARY UPTHRUST: 3,000LBS.
BEARING LIFE: B10/8800 HRS.
8. ROTATION: COUNTER-CLOCKWISE (VIEWED FROM TOP).
9. WITH NON-REVERSE RATCHET MECHANISM.
10. WITH GIB KEY: 0.375x0.375x2.875, 1PCS
11. NOISE: BELOW 85dBA AT 1 METER DISTANCE NO LOAD.
12. NATURAL REED FREQUENCY: 42HZ.
ABOVE CALCULATION IS CONSIDERING MOTOR AND FOR REFERENCE ONLY.
THE WHOLE PUMPING SYSTEM ANALYSIS SHALL BE PERFORMED BY THE PUMP MANUFACTURER.
13. MOTOR APPROX. WEIGHT: 1530 LBS.

- (A) OIL FILLER [UPPER BEARING]
- (B) OIL DRAIN [UPPER BEARING]
- (C) GREASE INLET NIPPLE [LOWER BEARING]

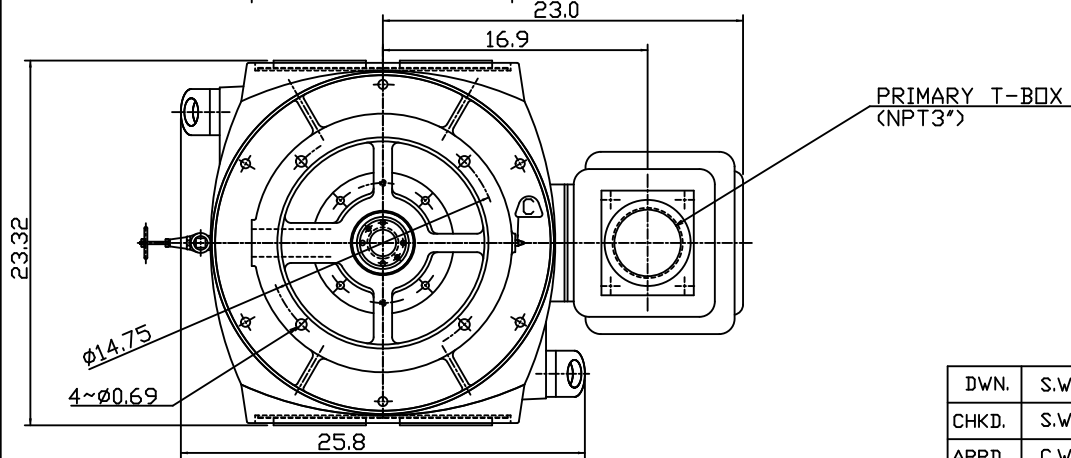
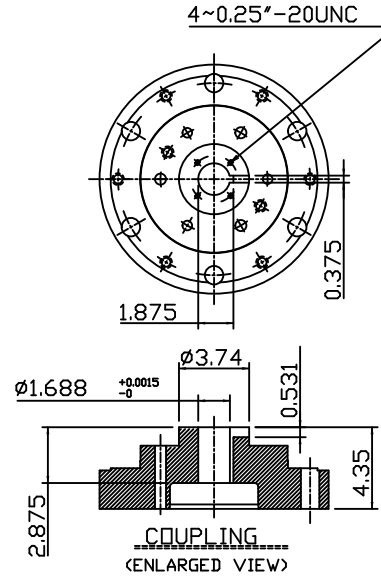
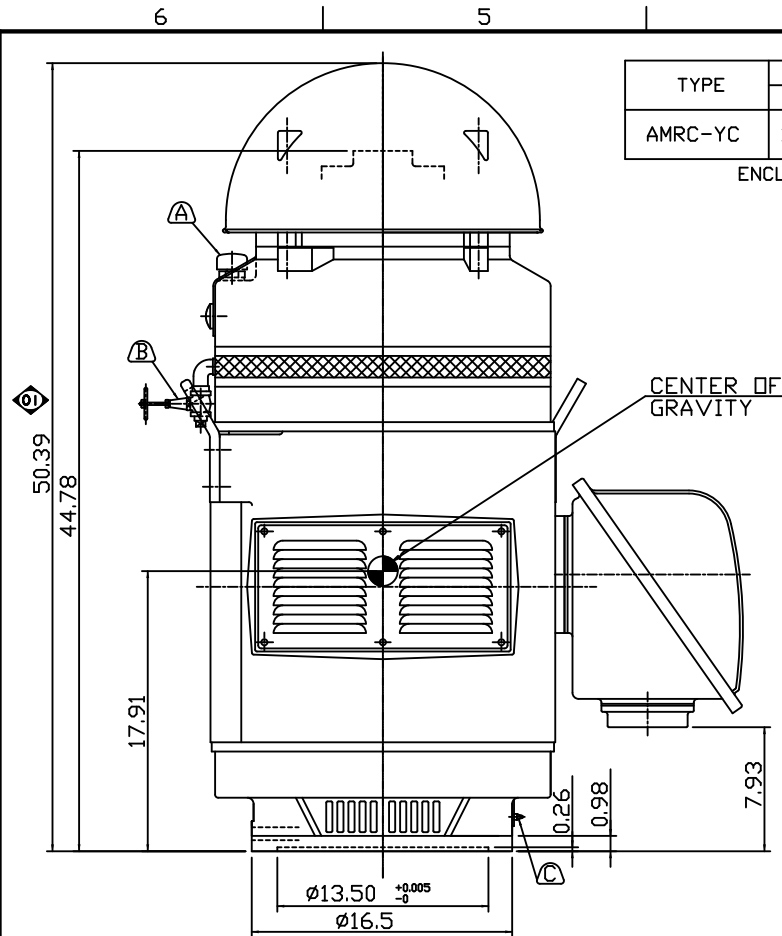

DATE	Jan. 14, 2009	OUTLINE DIMENSIONS	
CAT. #:	VH1504	3-PHASE INDUCTION MOTOR	
DWN.	S.WANG	NOV-10-2008	TEC Westinghouse
CHKD.	S.WANG	NOV-10-2008	
APPD.	C.WANG	NOV-12-2008	
DWG NO.			REV:01
3B040T441A			