

DATE
February 18, 2004
CATALOG NO.
DJPO402

OUTLINE DIMENSIONS
3-PHASE INDUCTION MOTOR

MOTOR TYPE:
ASGAJP
FRAME NO. 286JP

Pole	HP	kW	Hz	VOLT	Syn. Speed r/min(rpm)
2	40	29.8	60	230/460	3600

Ins	Rating	Dimension in	Approx Weight	Bearings
F	CONT.	inches	359 lbs.	DE: 6311ZZC3 NDE: 6211ZZC3

Open Protected Drip-Proof Type, Squirrel-cage Rotor.

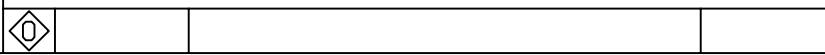
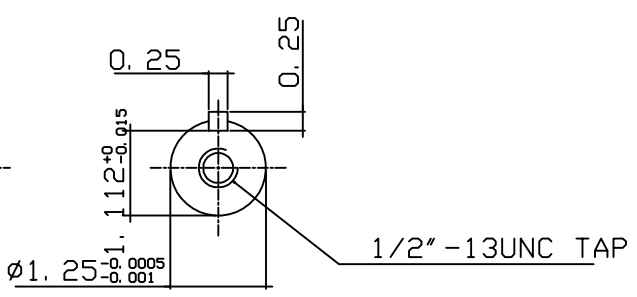
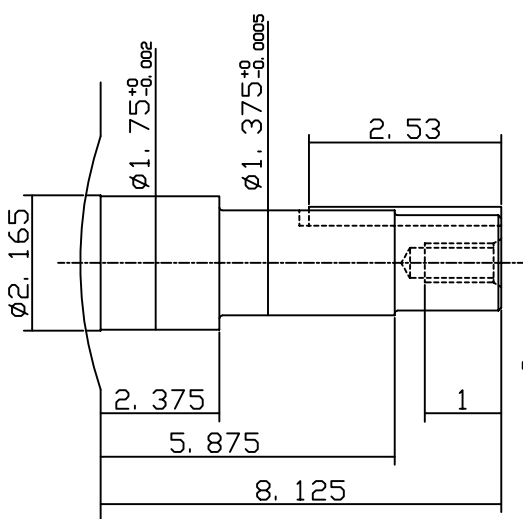
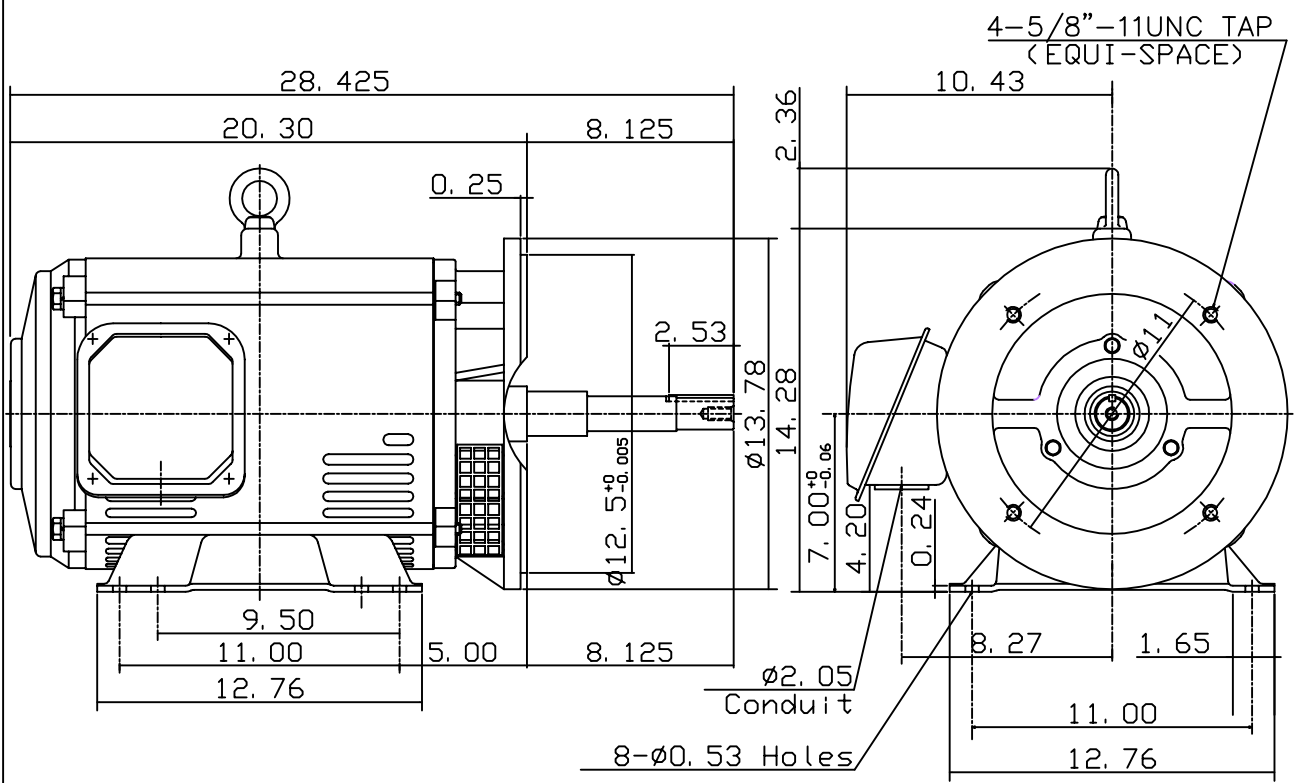

DWN.	J. T. HWANG	04-11-03
CHKD.	J. S. JEAN	04-11-03
APPD.	Y. B. HUANG	04-11-03



DWG NO.
31049U529523